

Bowl-Tronics Enterprises Incorporated

Address: 1115 Sherwood Ave.
Elgin IL. 60120
Website: www.bowl-tronics.com
E-mail: rick@bowl-tronics.com

Phone: 847-741-4500
Fax: 847-741-0914

Rake Trip Solenoid Assembly (RTSA)

Rake Trip Solenoid Assembly Theory

The (RTSA) is a device that works in conjunction with your infrared ball triggering system. It allows your Brunswick A-2 machine to have a quick rake drop without the need of any mechanical action to occur. When the infrared beam is blocked by a ball the triggering system tells the solenoid to pull in its plunger which in turns collapses the rake board.

Installation Instructions

Remember to remove power before performing any installation!!

Installing the (RTSA) to the shotgun

First, drop the rake by pulling on the trip latch. Next, slide the two "U" bolts over the top of the rake lift shaft, nick named the shotgun. One "U" bolt fits in front of the trip latch return spring mounting hole. Slide the solenoid bracket through the two "U" bolts and place the nuts on the bolts. Do not tighten down completely, only hand tighten the nuts. Slide the new solenoid bracket towards the trip latch until the "U" bolt is pushed up against the spring mounting hole and then tighten the "U" bolts down. Some adjustment may be need if the solenoid does not function properly. Remove the lock nut on bottom bolt that hold the trip latch to the shotgun. Remove the old 1/4" x 20 bolt and replace it with the new one provided. After running the bolt through the trip latch, slide two flat washers onto the bolt. Place the trip link from the (RTSA) onto the bolt and then add two more washers to the bolt then the lock not. Be sure not to over tighten the bolt. It must be able to move freely and make sure to lubricate often. If the top trip latch lock nut is not big enough for the trip lever from the (RTSA) to hit, replace it with the extension nut provided. *(See diagram for details)*

Making the electrical connections to your machine

First, start by running the black cable from the (RTSA) into the electrical box. Next, hook the white wire from the black cable to terminal # 1 of the low voltage terminal strip. Plug the black wire from the black cable to one wire from the infrared ball triggering, the other wire from the infrared ball triggering goes to the *tan or orange wire* that is off the secondary winding of the Brunswick transformer. The wire if tan or orange, usually isn't being used. *Note on converted A pinsetters hook the other wire to terminal #6.* Finally plug the power cord back into the machines electrical chassis and run the machine back to zero degrees. With the rake in the up position and the shotgun trip latch locked adjust the solenoid plunger by sliding the solenoid frame up or down on the mounting bracket. Adjust until you have approximately 1/4" inch of travel left on the plunger when the trip link makes contact with the extension nut on top of the trip latch. Sometimes you have to adjust the (RTSA) bracket to get the proper adjustment. *(See drawing for details) Be sure to lubricate the solenoid plunger often to reduce premature failure.*

Rake Trip Solenoid Assembly Diagram

Rake in up position with trip latch locked

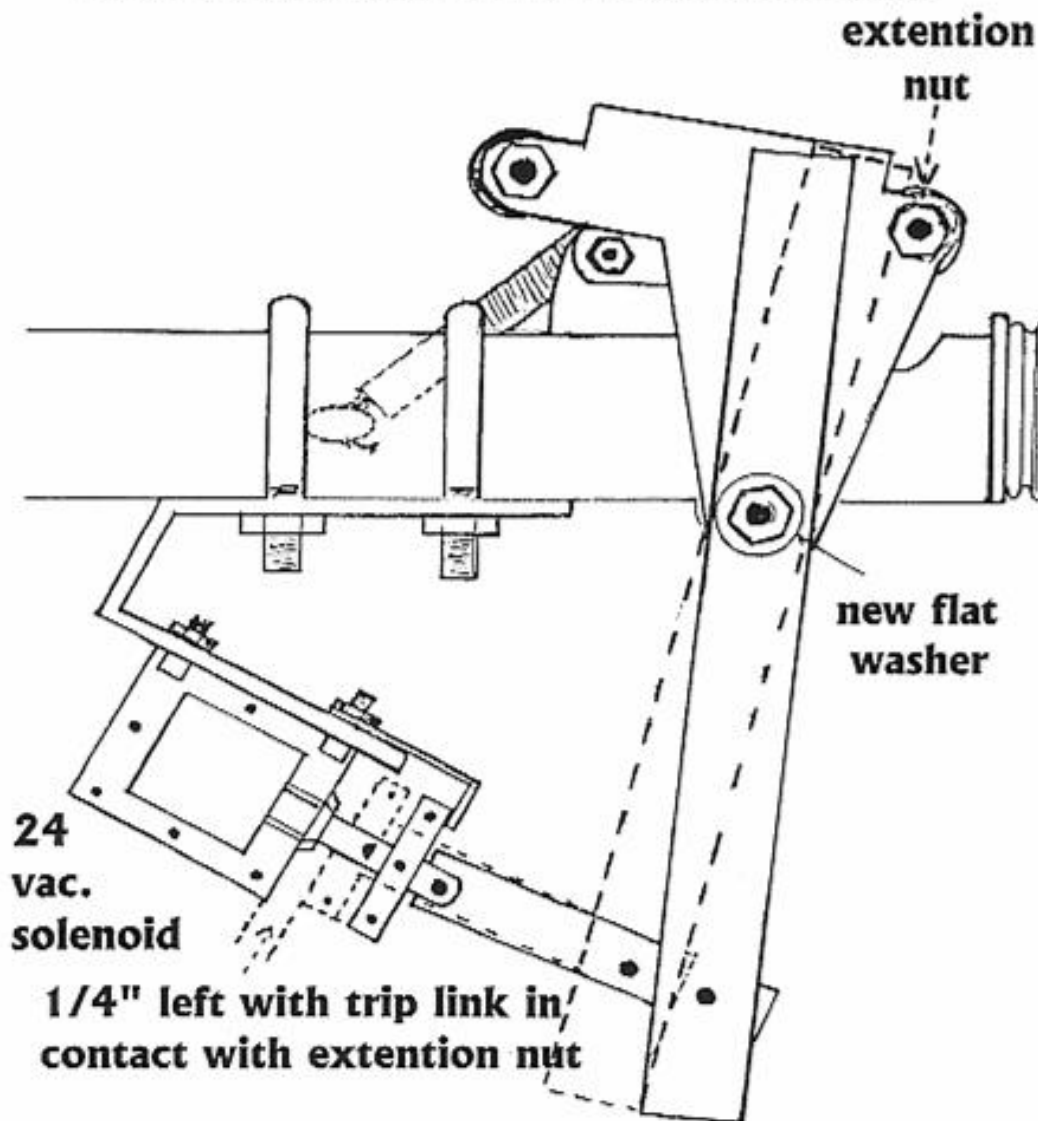

**lubricate moving parts weekly to prevent wear
remember this solenoid is used for every cycle**

For Repair Send Faulty Parts to:

**Address: BOWL-TRONICS
1115 Sherwood Ave.
Elgin IL. 60120**

**Phone: 847-741-4500
Fax: 847-741-0914**

Visit our web site at www.bowl-tronics.com

Notes:
