

# Bowl-Tronics Enterprises Incorporated

Address: 1115 Sherwood Ave  
Elgin IL. 60120  
Web site: [www.bowl-tronics.com](http://www.bowl-tronics.com)  
E-mail: [rick@bowl-tronics.com](mailto:rick@bowl-tronics.com)

Phone: 847-741-4500  
Fax: 847-741-0914

## ◆ M-4 Models: ECO, AUTO Infrared Triggering Unit ◆

---

### Theory of Operation

---

The M-4 Unit consists of three main parts. The Main Circuit Board (PCM), Relay Circuit Board (PCRDC, PCRAC, or PCR), and Transceiver (TC-KB, TC-SUB, TC-SUR). When a ball breaks the infrared beam the Transceiver sends a signal to the Main Circuit Board telling it a ball has passed. After processing the signal and after an adjustable amount of time, the Main Circuit Board tells the relay to cycle the machine. At some point in time during this operation the Main Circuit Board will also signal your scorer with the proper signal it needs to start the scoring process. When this signal is sent, and the type of signal, depends on the particular scoring system your bowling center has.

### Main Circuit Board (PCM)

---

This card performs all of the detection, triggering, delay, and autoscore functions. The Main Circuit Board has two adjustable thumbwheel potentiometers located on the lower left and upper right corners of the circuit board. These control the amount of time between the ball breaking the infrared beam and when the machine is cycled. Turn the wheel in towards the center of the card for less delay or out towards the edge for more delay. The delay time can be adjusted from 0 to 6 seconds. This card may also have a smaller card attached to it; this is for the autoscore output. The type of autoscore card you receive will depend on the particular type of autoscore your bowling center has.

### Relay Circuit Board (PCRDC, PCRAC or PCR)

---

This circuit board, which is the smaller of the two inside the M-4 unit, performs the actual triggering of the machine. It is basically just a pair of relays that the Main Circuit Board tells to close, thus triggering your machine. There are three different kinds of relay cards. The exact model you receive will depend on the type of machine you are installing your units on.

- PCRDC This card is used on Brunswick A-2 machines and uses transistors for the triggering
- PCRAC This card is used on Brunswick A machines and uses Triacs for the triggering
- PCR This card is used on all AMF and BRC machines and uses relays for the triggering

### Transceiver (TC-KB, TC-SUB or TC-SUR)

---

The Transceiver contains the phototransistors and infrared emitting diodes. When mounted on the kickback or capping the Transceiver projects a beam of infrared light across the lane which is reflected back by the reflector. When a ball breaks this beam the Transceiver sends a signal to the Main Circuit Board letting it know a ball has passed the beam.

### Block out Switches (optional)

---

The Block out Switches, which are only used on Brunswick machines, are micro switches that mount on the 4 to 1 shaft of the gear box. When the machine cycles the Block out Switch closes, effectively disabling the M-4 unit from triggering the machine a second time. This is very useful when the Transceiver is mounted behind the sweep. When the sweep breaks the infrared beam the machine is already in operation so any signal the Main Circuit Board receives is ignored.

◆ M-4 Models: ECO, AUTO Infrared Triggering Unit Diagram ◆

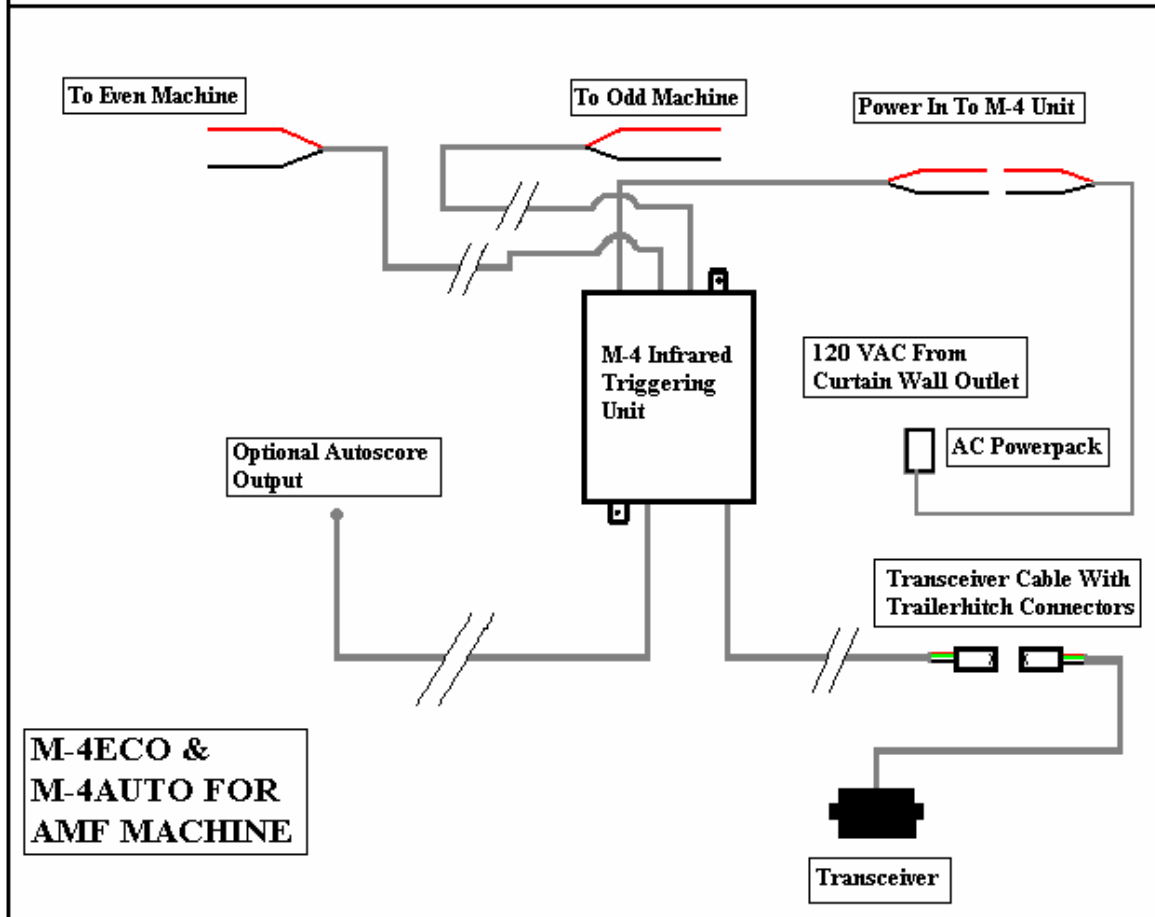
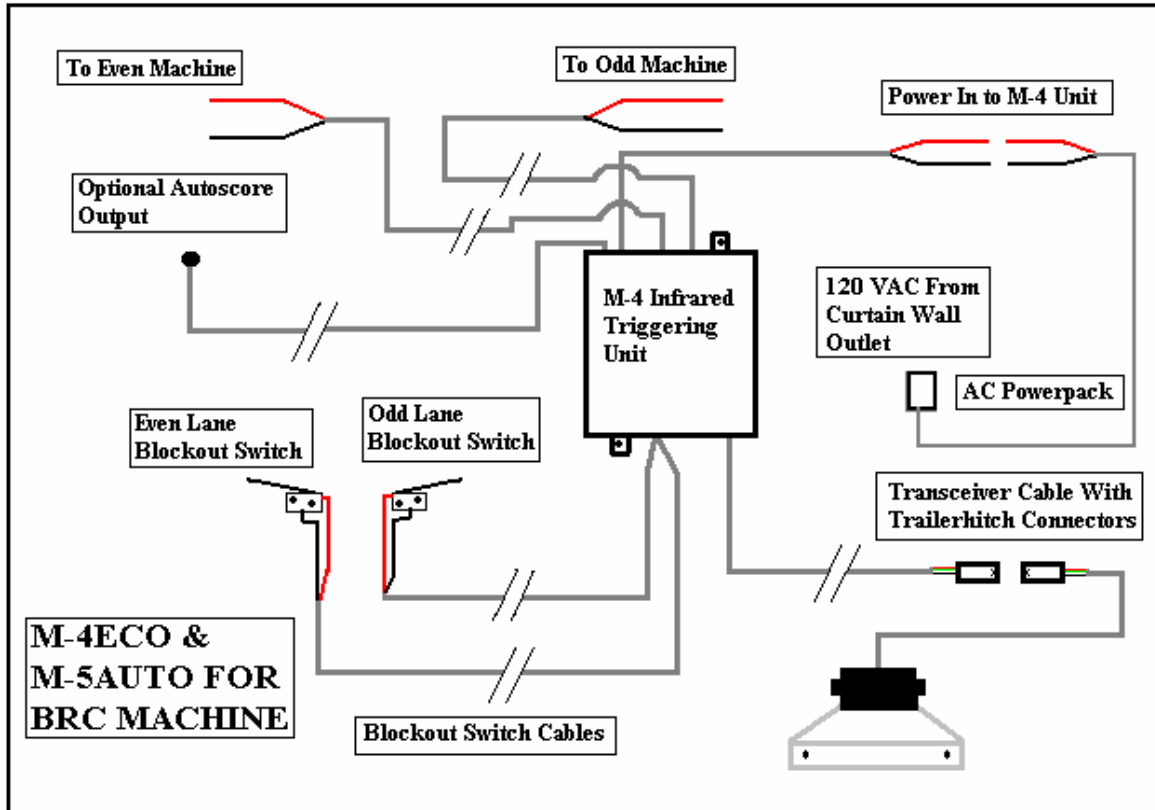

# ◆ Installation Instructions ◆

*Before Performing Any Installation Make Sure That Power Is Removed From the Machine By Unplugging The Power Cord From The Electrical Chassis!!*

## Mounting the M-4 Unit

The M-4 Triggering Unit mounts on the curtain wall, between the pair of machines, just above the masking unit. A power pack is provided with your unit that plugs into a 120 volt outlet located on the curtain wall. Please refer to the installation guide on page two when installing your units. After the M-4 unit is mounted on the curtain wall consult the instructions for your particular machine.

## Brunswick Machine Installation

### The Model A-2 Machine

Once your M-4 unit is mounted on the curtain wall run the two output cables to each machines electrical control chassis. One output cable will be marked “L”, this is for the left or odd machine (1, 3, 5, etc.), the other output cable will run to the right or even machine (2, 4, 6, etc.). Run each output cable to the time delay module inside your electrical chassis. The red wire will connect to terminal #16 on your time delay module using the dual tab connector supplied with your unit. The black wire will connect to terminal #18 on your time delay module, also using the dual tab connector. Leave the wires that are already connected to the time delay module. *Note!! You must leave your rake trigger switch connected to the time delay module. If you don't have a rake trigger switch, hook the red wire to terminal #16 and your black wire to terminal #17.*

Mount the Transceiver on the kickback or capping (see page #12 illustrations) and the reflector straight across from it. Although the Transceiver emits a wide infra red beam, try to make it point as straight as possible at the reflector. If the Transceiver is pitched up or down, this will affect the operation of the unit much more than if it is pointed to the left or right of the reflector. Also, try to mount all Transceivers and reflectors in a straight line all the way across your bowling center. Mounting everything straight and level can solve many problems in the future. A string run across the bowling center can be an easy guide for mounting Transceivers and reflectors. The Transceiver will have a white trailer hitch connector which plugs into the corresponding trailer hitch connector from the M-4 unit.

If your M-4 unit has Block out Switches mount them on the 4 to 1 (see page #11, illustration #1). The two wire cable from the Block out Switches each run to the M-4 unit. Make sure the cable marked “L” is on the odd numbered machine.

You can now plug in the power pack to the 120 volt outlet on the curtain wall. The two wire cable from the power pack then runs to the M-4 unit and plugs into the short two wire cable from the M-4 unit.

◆ For all autoscore hookups please consult the autoscore section of this manual. ◆

# The Model A Machine

---

Once your M-4 unit is mounted on the curtain wall run the two output cables to each machines electrical control chassis. One output cable will be marked “L”, this is for the left or odd machine (1, 3, 5, etc.), the other output cable will run to the right or even machine (2, 4, 6, etc.). Connect the red wire to terminal #1 on the low voltage terminal strip and the black wire to terminal #11, also on the low voltage terminal strip.

Mount the Transceiver on the kickback or capping (see page #12 illustrations) and the reflector straight across from it. Although the Transceiver emits a wide infra red beam, try to make it point as straight as possible at the reflector. If the Transceiver is pitched up or down, this will affect the operation of the unit much more than if it is pointed to the left or right of the reflector. Also, try to mount all Transceivers and reflectors in a straight line all the way across your bowling center. Mounting everything straight and level can solve many problems in the future. A string run across the bowling center can be an easy guide for mounting Transceivers and reflectors. The Transceiver will have a white trailer hitch connector which plugs into the corresponding trailer hitch connector from the M-4 unit.

If your M-4 unit has Block out Switches mount them on the 4 to 1 (see page #11, illustration #1). The two wire cable from the Block out Switches each run to the M-4 unit. Make sure the cable marked “L” is on the odd numbered machine.

You can now plug in the power pack to the 120 volt outlet on the curtain wall. The two wire cable from the power pack then runs to the M-4 unit and plugs into the short two wire cable from the M-4 unit.

It is recommended that the cycle solenoid on the A machine be modified so it will not pull so hard on the trip link. This can be accomplished by placing a stop bracket in front of the plunger (see page #11, illustration #2). Drill a hole in the solenoid mounting bracket in front of the plunger. Mount the stop bracket and slide the plunger into the solenoid until it just starts to pull on the trip latch. Slide the stop bracket up to the plunger and tighten it down. This method keeps the plunger from coming all the way out. With the plunger’s travel distance cut down it won’t pull so hard, cutting down on wear and tear on both the solenoid and the trip latch. The reason for this modification is that the cycle solenoid was not engineered to withstand energizing every cycle. This modification will add many years to the life of your cycle solenoid.

(Note!!!! If installing a Bowl-Tronics 24 VAC solenoid assembly instead of the BRC (A) high voltage solenoid follow these directions.) First, remove the high voltage solenoid and replace with the new 24 VAC solenoid w/bracket. Second, feed the new 2 conductor SJOW cable into the chassis and hook one wire to terminal #9 and the other wire to terminal #11.

◆ For all autoscore hookups please consult the autoscore section of this manual. ◆

# AMF Machine Installation

## Installation for all AMF Machines

---

Once your M-4 unit is mounted on the curtain wall run the two output cables to each machines TBA or AMC box. One output cable will be marked “L”, this is for the left or odd machine (1, 3, 5, etc.), the other output cable will run to the right or even machine (2, 4, 6, etc.). Run each output cable to the tenth frame button inside the TBA or AMC box. The two wire output cables connect in parallel with the tenth frame reset button. The colors do not matter as this is just point closure.

Mount the Transceiver on the kickback or capping (see page #12 illustrations) and the reflector straight across from it. Although the Transceiver emits a wide infra red beam, try to make it point as straight as possible at the reflector. If the Transceiver is pitched up or down, this will affect the operation of the unit much more than if it is pointed to the left or right of the reflector. Also, try to mount all Transceivers and reflectors in a straight line all the way across your bowling center. Mounting everything straight and level can solve many problems in the future. A string run across the bowling center can be an easy guide for mounting Transceivers and reflectors. The Transceiver will have a white trailer hitch connector which plugs into the corresponding trailer hitch connector from the M-4 unit.

You can now plug in the power pack to the 120 volt outlet on the curtain wall. The two wire cable from the power pack then runs to the M-4 unit and plugs into the short two wire cable from the M-4 unit.

◆ For all autoscore hookups please consult the autoscore section of this manual. ◆

*(Bottom intentionally left blank)*

# ◆ Autoscore Section ◆

---

## Connecting Your Scoring

---

After connecting all of the other wires to your machine and M-4 unit follow the instructions for your particular type of scoring and machine. Take care in making your autoscore connections, as this can help speed up the process and minimize scoring problems.

## 12 Strike Scoring

---

There will be a five conductor cable for the autoscore. This cable will have a white trailer hitch connector on the end. The connections will be made with the other end of the trailer hitch connector for easy plug in and out. Run the cable to the IDC5 Relay Rack. The connections are as follows:

### ◆ 10<sup>th</sup> Frame Hook Up ◆

- Red (common) ⇒ Pin 2 on ODC5 (Left and Right Machine)
  - Green ⇒ Pin 1 on ODC5 (Right Machine)
  - Brown ⇒ Pin 1 on ODC5 (Left Machine)
- (Pin 2 on ODC5 should be the emitter of the transistor)

### ◆ Autoscore Input ◆

- Red (common) ⇒ Pin 2 on IDC5 (Left and Right Machine)
- Orange ⇒ Pin 1 on IDC5 (Left Machine)
- Black ⇒ Pin 1 on IDC5 (Right Machine)

## 12 Strike Scoring for Ball Speed Units

---

### ◆ 10<sup>th</sup> Frame Hook Up ◆

- Black (common) ⇒ Pin 2 on ODC5 (Left and Right Machine)
  - Green ⇒ Pin 1 on ODC5 (Right Machine)
  - Brown ⇒ Pin 1 on ODC5 (Left Machine)
- (Pin 2 on ODC5 should be the emitter of the transistor)

### ◆ Autoscore Input ◆

- Red (Common) ⇒ Pin 2 on IDC5 (Left and Right Machine)
- Orange ⇒ Pin 1 on IDC5 (Left Machine)
- Yellow ⇒ Pin 1 on IDC5 (Right Machine)

*(Note!!! On ball speed installations the two Transceivers must be mounted three feet apart.)*

## AMF Autoscore with K-1 Relays on Brunswick Machines

---

The two wire machine output cables that run to the Electrical chassis will run to the K-1 relay instead of the low voltage terminal strip or the time delay module. The connection will be in parallel with the time delay relay. Make connections as follows:

- Red wire ⇒ Terminal 5 on the K-1 Relay
- Black wire ⇒ Terminal 8 on the K-1 Relay

## AMF Magicscore on Brunswick Machines

---

There will be a three conductor autoscore cable from the unit, colored Red, Black, and White. This will supply the scoring with 12 volts DC APS Output. The black and white wires will switch ground on and off when a ball passes the Transceiver.

We also recommend that you replace the AMF Time Delay Module and install a new solid state relay for cycling of the machine.

- Red wire                   ⇒     12 VDC (common)
- White wire               ⇒     Right Output
- Black wire               ⇒     Left Output

## AMF Accuscore on Brunswick or AMF Machines

---

This unit will have a four conductor autoscore cable. The red and black wires are for the odd machine while the green and white wires are for the even machine.

- On Brunswick machines tie the wires into where the old APS Relay points were
- On AMF machines tie the wires parallel to the rake start switch

## Brunswick Autoscore on Brunswick or AMF Machines

---

### AS-80 w/79 Scanners

This unit will have a three wire autoscore cable with a white Molex connector on the end. The Molex connector connects to the DA Board in place of the old optics. The M-4 adapter card takes 5 volts dc from the DA board and sends it into to optocouplers. The 5 volts dc is then sent back to the DA board for both right and left ball detect. When a ball passes the Transceiver the 5 volts dc will drop to zero and start the scanner.

- *The time delay for taking data must be set so that the scorer takes data before the table comes down on the pins. If you are still having scoring trouble wire the data take relay as shown in manual.(See page #13).*

### AS-90 & Frameworx w/86 Scanners or CCD Cameras

This unit will have 2 white Molex connectors on the end. Red, Black, and White are for the left optic and Orange, Blue, and Yellow are for the right optic. These will replace both sets off Brunswick's infrared optics. Note!! If you have 86 Scanners the hook up is the same except there will only be Red and Black wire for the left optic and Orange and Blue wire for the right optic. With this setup you will need only one optical head per pair. This hook up is optional and the M-4 outputs can be used as either the main or as a backup. This system takes 5 volts dc from Brunswick's optic cable and sends it to the camera. This voltage is kept off until a ball passes the Transceiver, at which time it rises to 5 volts dc to signal the camera or scanner.

- *The time delay for taking data must be set so that the scorer takes data before the table comes down on the pins. If you are still having scoring trouble wire the data take relay as shown in manual. (See page #13)*

# Optional Data Take for AMF Machines

---

This unit will have 2 three conductor autoscore cables that replace the 44/144 and 0 degree switch. The output from this cable is adjustable for setting your data take timing. You will need to splice into the D/A PCB connector cable. The new pins solenoid is not needed. The 24 volts AC input to the scorer must be supplied by the machine when it is turned on. Follow the DA PCB connector schematic for all of your connections and color code matching. (See schematic below)

<b>D/A PCB Connector 11-696791 Schematic</b> <b>Hook up to eliminate NPS Left and Right Cable Connector</b>
--

• Lane 1 Input from Machine and M-4 Unit •

<u>Connector</u>	⇒	<u>Machine</u>
• Terminal #10 (Black wire)	⇒	• 24 VAC from machine
• Terminal #11 (White wire)	⇒	• 24 VAC from machine
• Terminal #17 (Yellow wire)	⇒	• White wire from M-4 unit (0 degree)
• Terminal #18 (Violet wire)	⇒	• Black wire from M-4 unit (44/144 degree)
• Terminal #14 (Brown wire)	⇒	• Red wire from M-4 unit (common)

• Lane 2 Input from Machine and M-4 Unit •

<u>Connector</u>	⇒	<u>Machine</u>
• Terminal #1 (Black wire)	⇒	• 24 VAC from machine
• Terminal #2 (White wire)	⇒	• 24 VAC from machine
• Terminal #8 (Yellow wire)	⇒	• White wire from M-4 unit (0 degree)
• Terminal #9 (Violet wire)	⇒	• Black wire from M-4 unit (44/144 degree)
• Terminal #5 (Brown wire)	⇒	• Red wire from M-4 unit (common)

The 24 volts AC coming from the machine is only sent when the machine is turned on. This voltage can be supplied by a small transformer with a 120 volt primary and a 24 volt secondary. In 82-30 machines the connection for the primary is at J2 and J8. For 82-70 machines the primary can tap off the pit light or the rear motor connection.

# ◆ Troubleshooting Guide ◆

---

## Troubleshooting the M-4 Unit

---

If a problem arises with your M-4 unit the easiest way to find the problematic part is to use the substitution method. From a unit that you know to work properly try swapping each component one at a time until the unit works. So if your unit is malfunctioning and you replace the Transceiver and the unit works again you know that the Transceiver is at fault and can be sent back to Bowl-Tronics for service. The same holds true for each individual component (Main Circuit Board, Relay Board, Transceiver, and Block out Switches). If you replaced each component and the unit still does not operate the most likely cause is that it is wired improperly.

## You Experience Random Triggering On Either or Both Lanes

---

- Double check your wiring
- Make sure Transceiver is properly aligned (Purchase a TATPC for proper alignment)
- Check that the reflector is clean
- Try swapping components that you know to work

## Mismatched Components

---

If your center has M-4 Triggering Units installed prior to 1996 they may have a different type of PCM and Transceiver that is not compatible with the new system. The easiest way to tell is to look at the PCM where it plugs into the connector. The older type board has a large resistor that resembles a cement block near the edge where it plugs into the connector, the newer board does not. The new type Transceiver will have five wires attached to the trailer hitch connector while the older type will have eight attached to it. If you have multiple types of systems make sure that the new type PCM is used in conjunction with the new type Transceivers. The old type PCM must be used with the Old type Transceiver.

The most common type of malfunction you will find if the older and newer types are used in the same unit is that one side will trigger constantly while the other side will work fine. BOWL-TRONICS still manufactures and repairs both types of boards and Transceivers so you are not stuck if you do have a mismatch although we do recommend upgrading to the newer system. The actual unit that everything plugs into is still the same.

## Basic Troubleshooting

---

Visually inspect your M-4 to be sure that all proper connections are made. Many problems can be solved by changing the Transceiver and making sure that it is aligned properly. The reflectors also play a large part. If the reflector is dirty it will fail to reflect the infrared beam back to the Transceiver. Also, make sure that the wiring in the machine is correct (especially in Brunswick machines)

As with all electronic goods, parts do fail. At Bowl-Tronics we buy only the highest quality electronic parts available to us. Your M-4 should give you many years of reliable service. If in the event your M-4 does fail to operate correctly, you should call Bowl-Tronics at the number listed on the next page.



# ◆ Brunswick Illustrations ◆

## 4 To 1 Block out Switch Mounting On Brunswick Machine

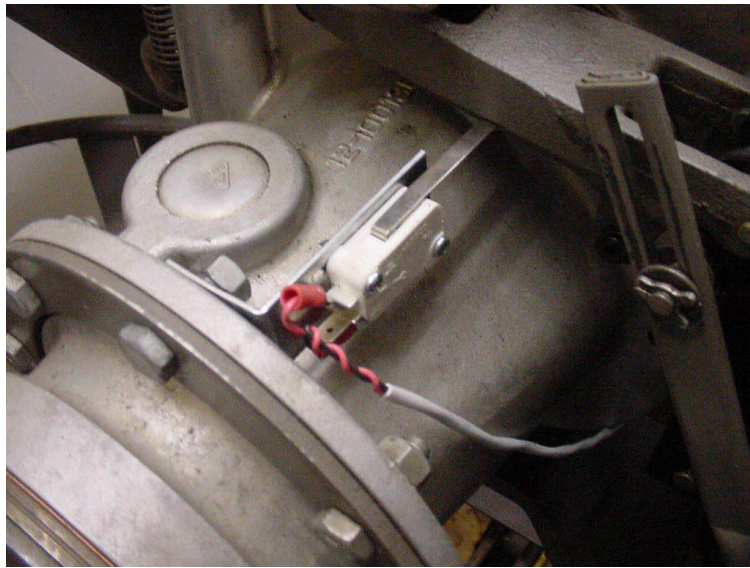
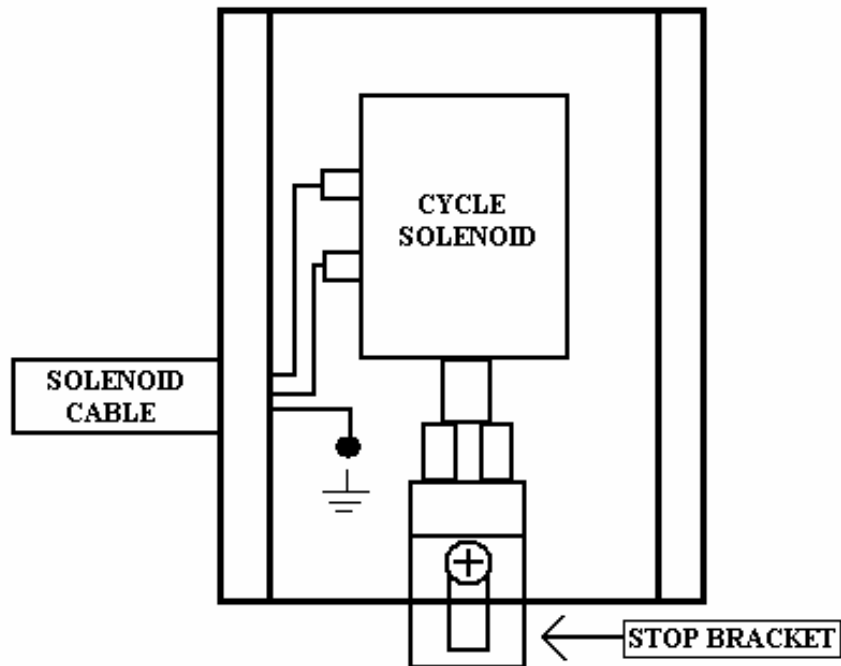

ILLUSTRATION SHOWS LEVER IS DEPRESSED AT 0 DEGREES AT IDLE

## Stop Bracket on Brunswick “A” Cycle Solenoid



STOP BRACKET REDUCES THE PLUNGER TRAVEL PREVENTING IT FROM PULLING SO HARD ON THE CLUTCH TRIP LEVER

**MOUNT TRANSCEIVER LEVEL AND STRAIGHT ACROSS FROM REFLECTORS**

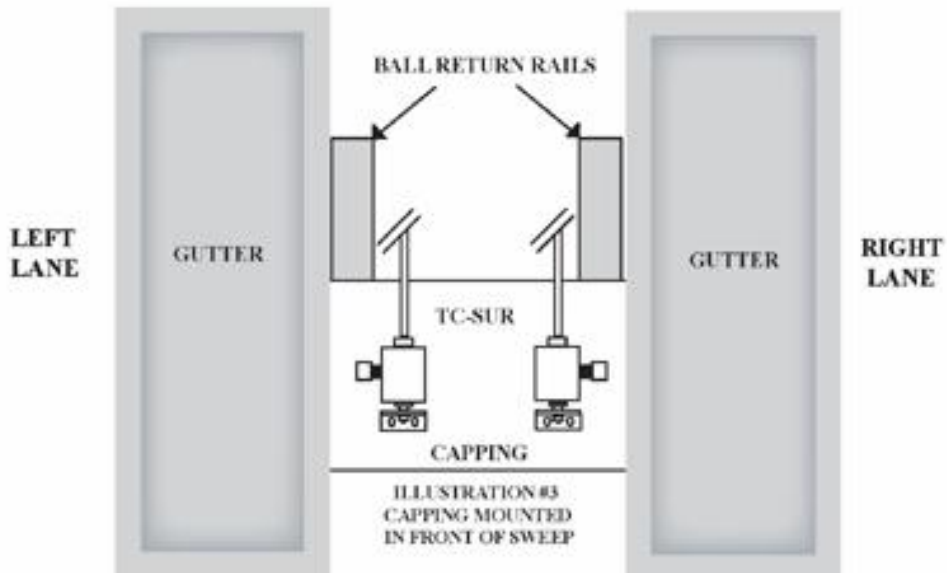
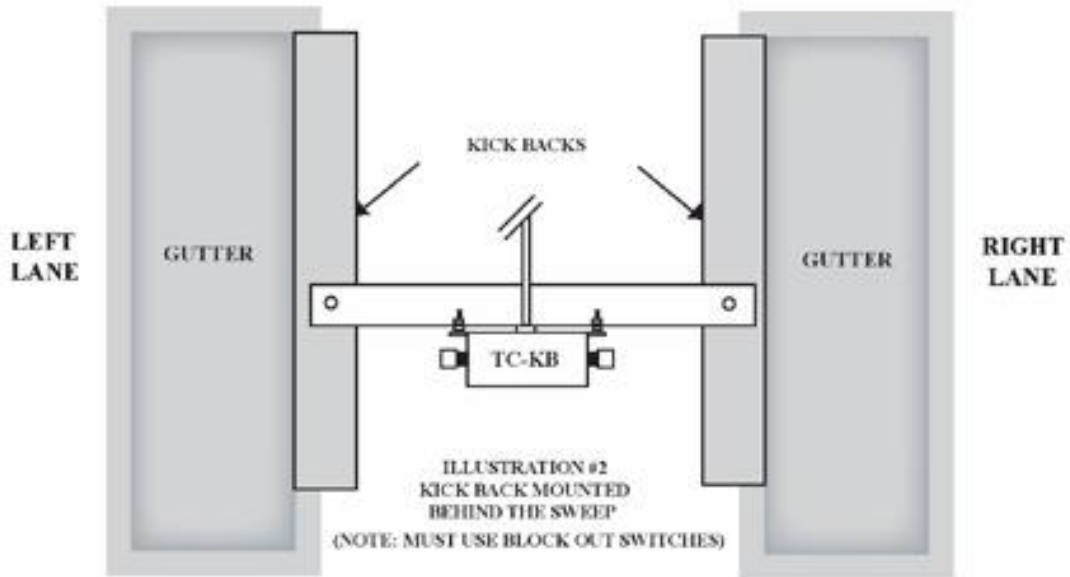
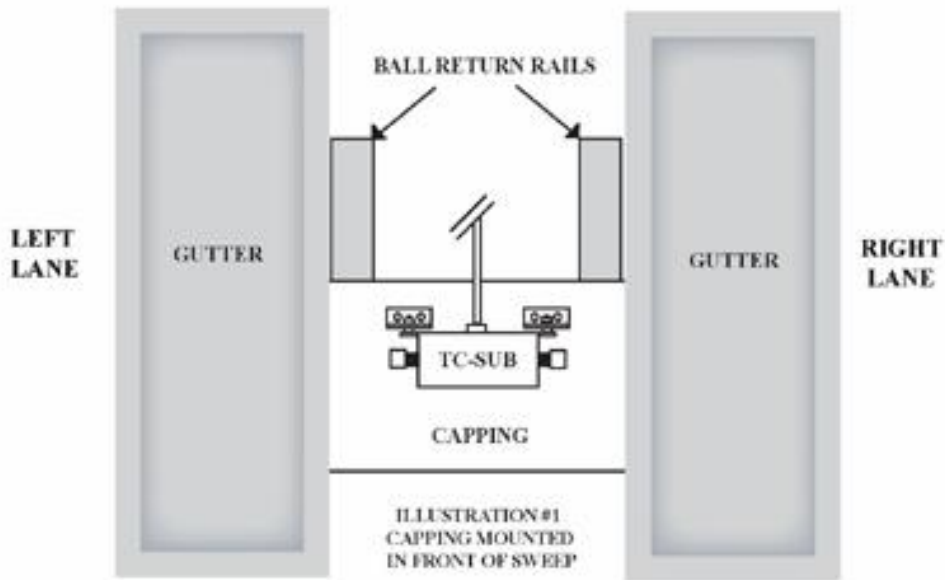

# ◆ Brunswick Schematic ◆

## Data Take Relay Hook Up On Brunswick "A-2" Machine

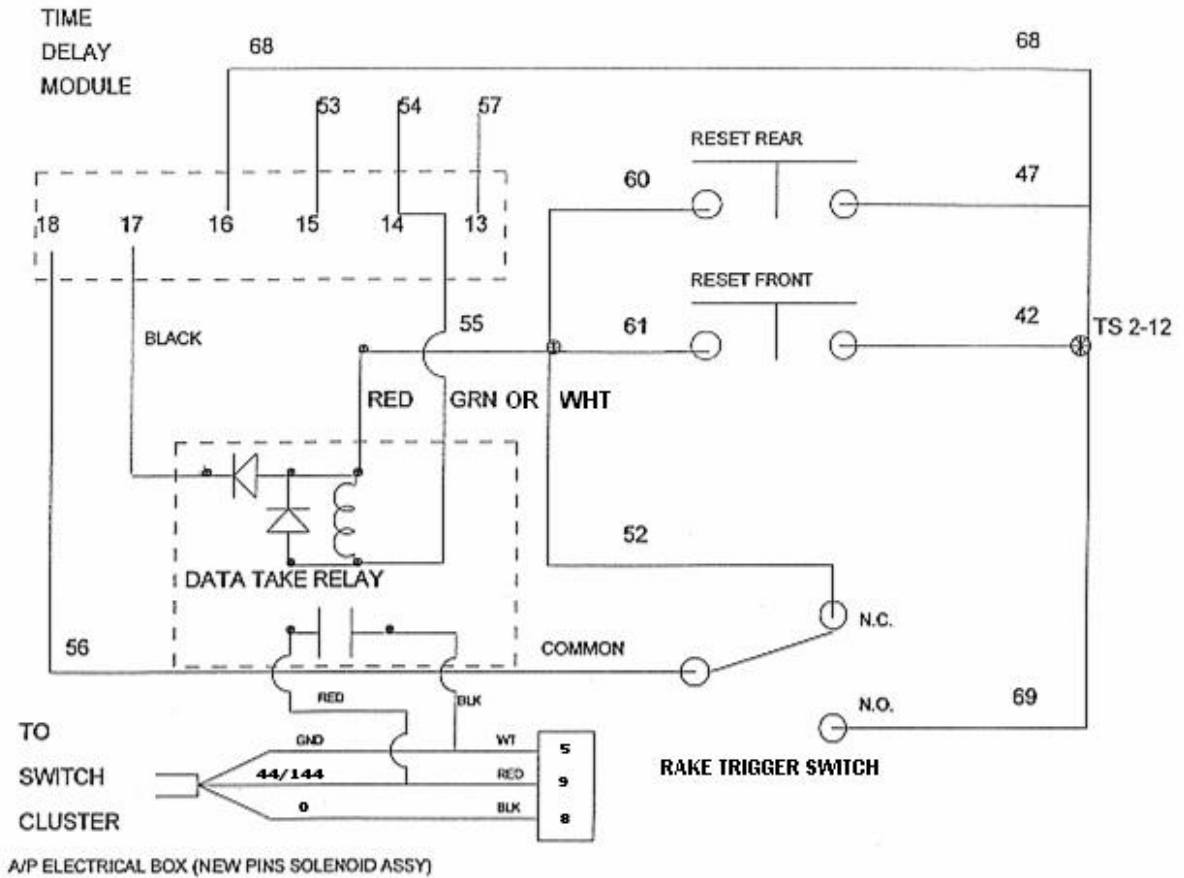

UNPLUG WIRE # 55 OFF TERMINAL 17 ON TIME DELAY MODULE. PLUG BLACK WIRE FROM DATA TAKE RELAY ON TERMINAL 17. PLUG RED WIRE FROM DTR INTO WIRE # 55. PLUG GREEN WIRE FROM DTR INTO TERMINAL # 14 ON TIME DELAY MODULE USING DUAL TAB CONNECTOR.

## Data Take Relay Hook Up On Brunswick "A" Machine

