

# Bowl-Tronics Enterprises Incorporated

Address: 1115 Sherwood Ave  
 Elgin IL. 60120  
 Web site: [www.bowl-tronics.com](http://www.bowl-tronics.com)  
 E-mail: [rick@bowl-tronics.com](mailto:rick@bowl-tronics.com)

Phone: 847-741-4500  
 Fax: 847-741-0914

## ◆ Bowl-Tronics Sentinel Series 1 Infrared Foul Unit ◆

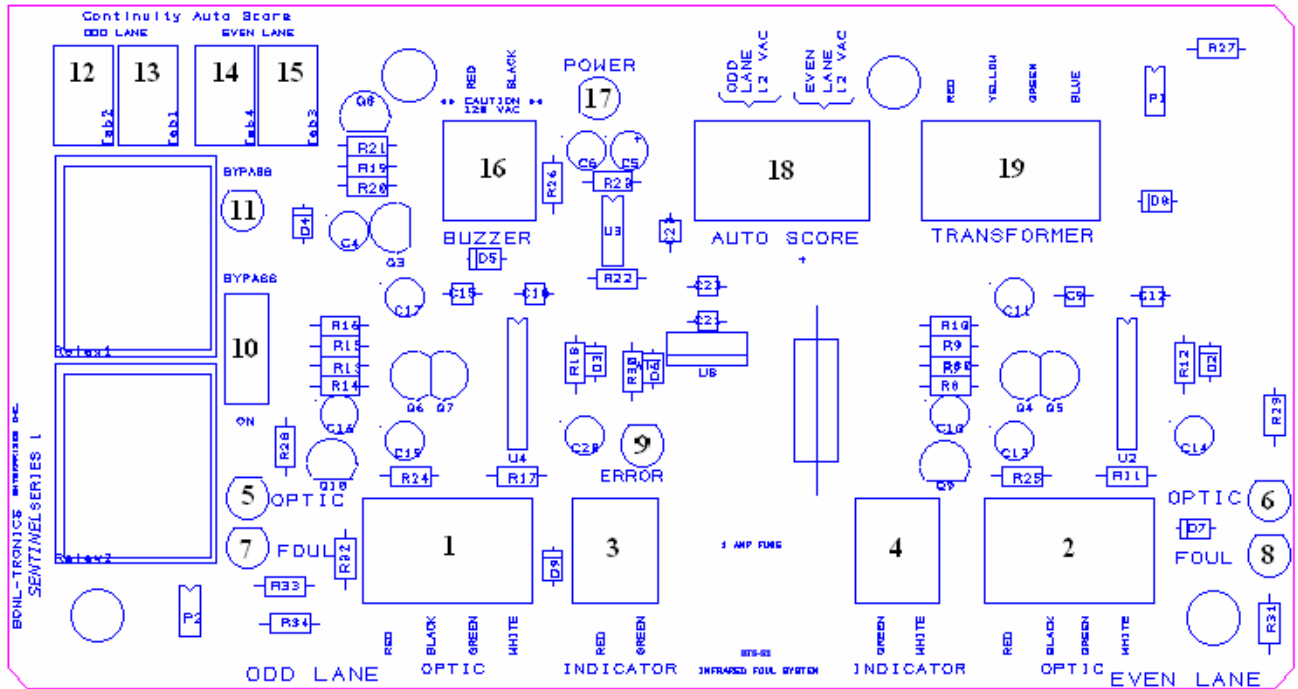

### PC Board Layout Description Table:

1. Odd lane infrared optic
2. Even lane infrared optic
3. Odd lane indicator light socket
4. Even lane indicator light socket
5. Odd lane optic alignment LED
6. Even lane optic alignment LED
7. Odd lane foul indicator LED
8. Even lane foul indicator LED
9. Error indicator LED (*see manual for details*)
10. Bypass switch (*see manual for details*)
11. Bypass switch indicator LED
12. & 13. Odd lane autoscore point closure output
14. & 15. Even lane autoscore point closure output
16. Buzzer output
17. Power indicator LED
18. Odd & even 12 VAC autoscore output
19. Transformer input

# ◆ BTS-S1 Infrared Foul Unit Diagram ◆

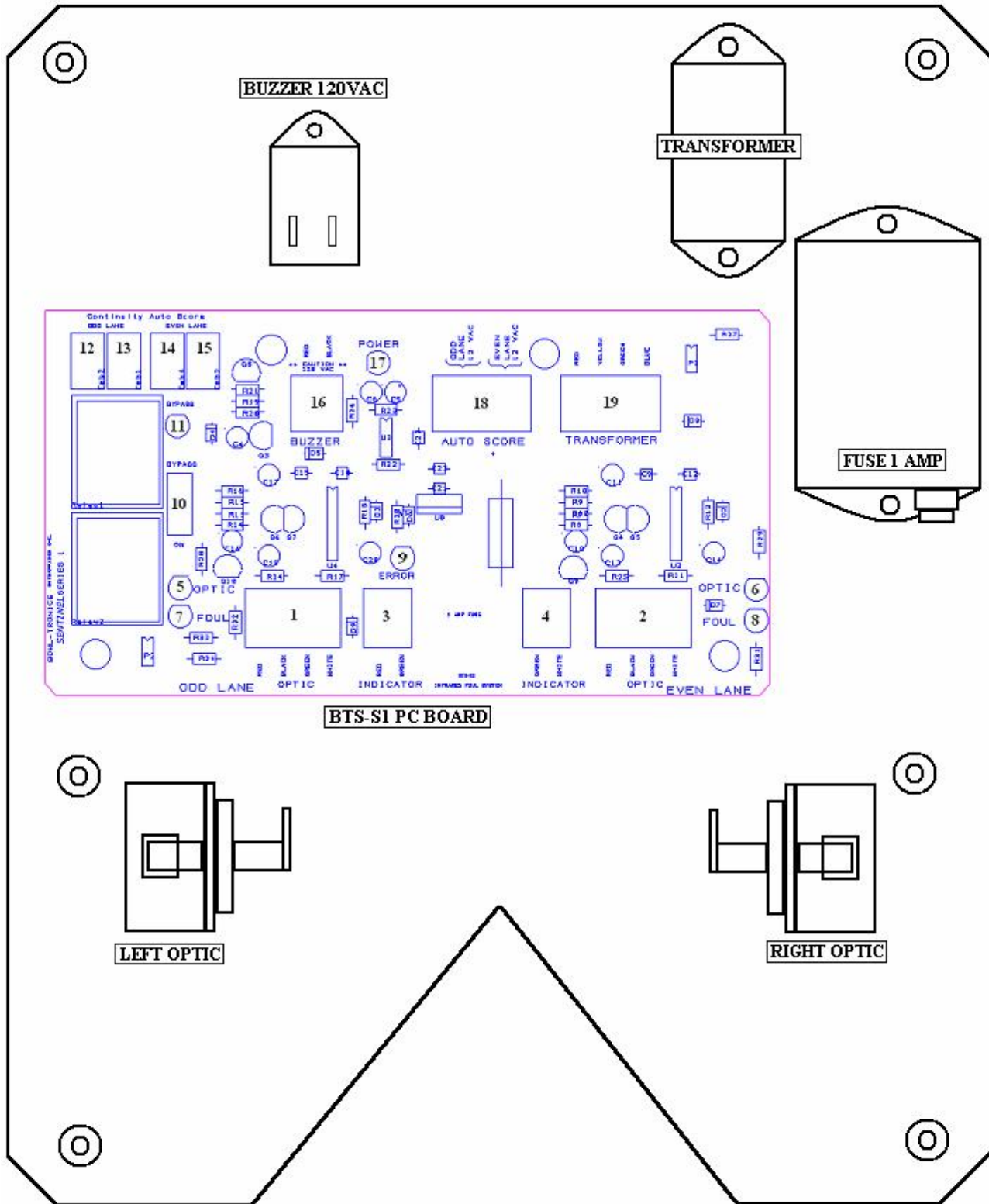

**Brunswick large division cover foul units**

# ◆ BTS-S1 Infrared Foul Unit Diagram ◆

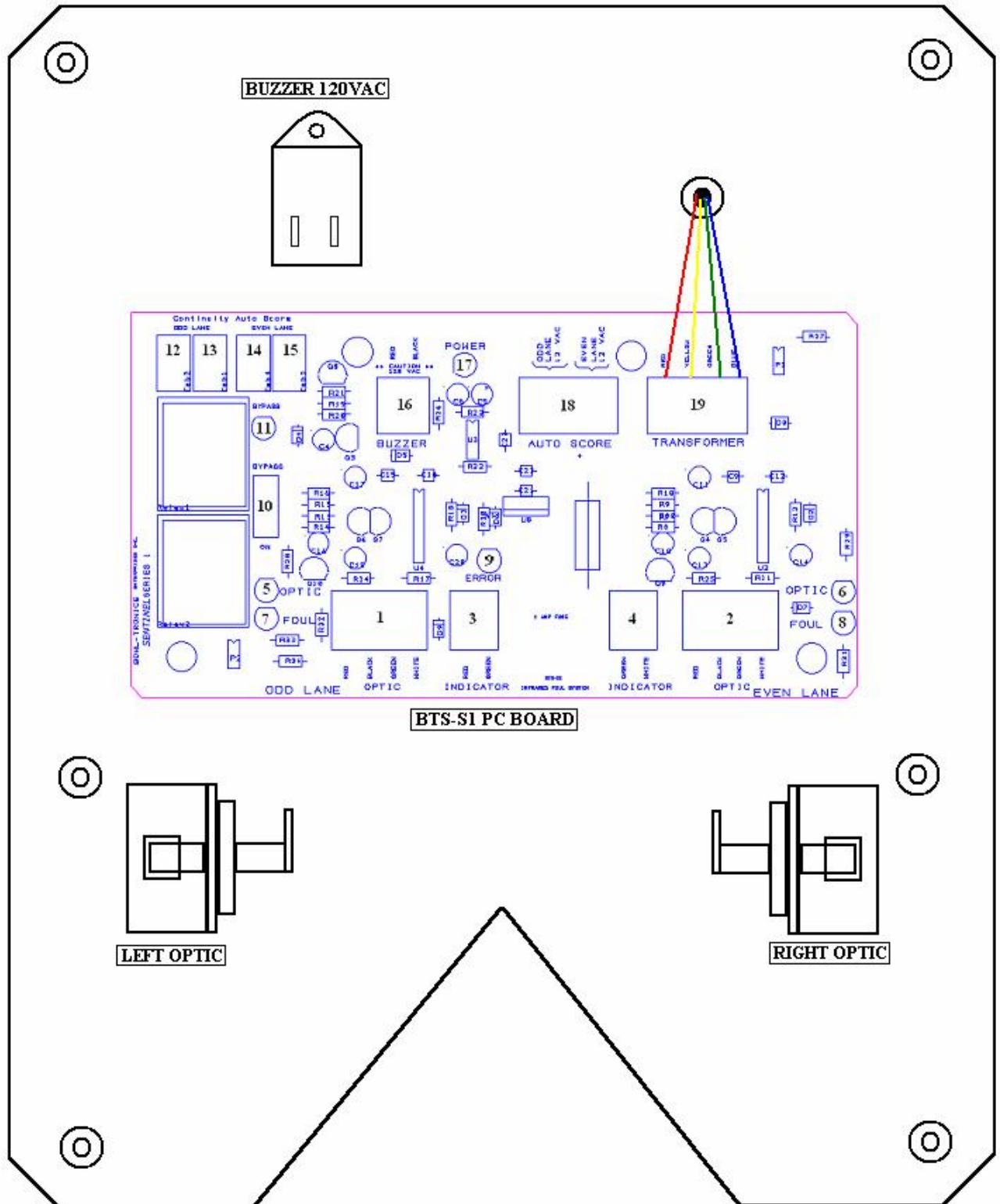

**Brunswick narrow large division cover foul units**

# ◆ BTS-S1 Infrared Foul Unit Diagram ◆

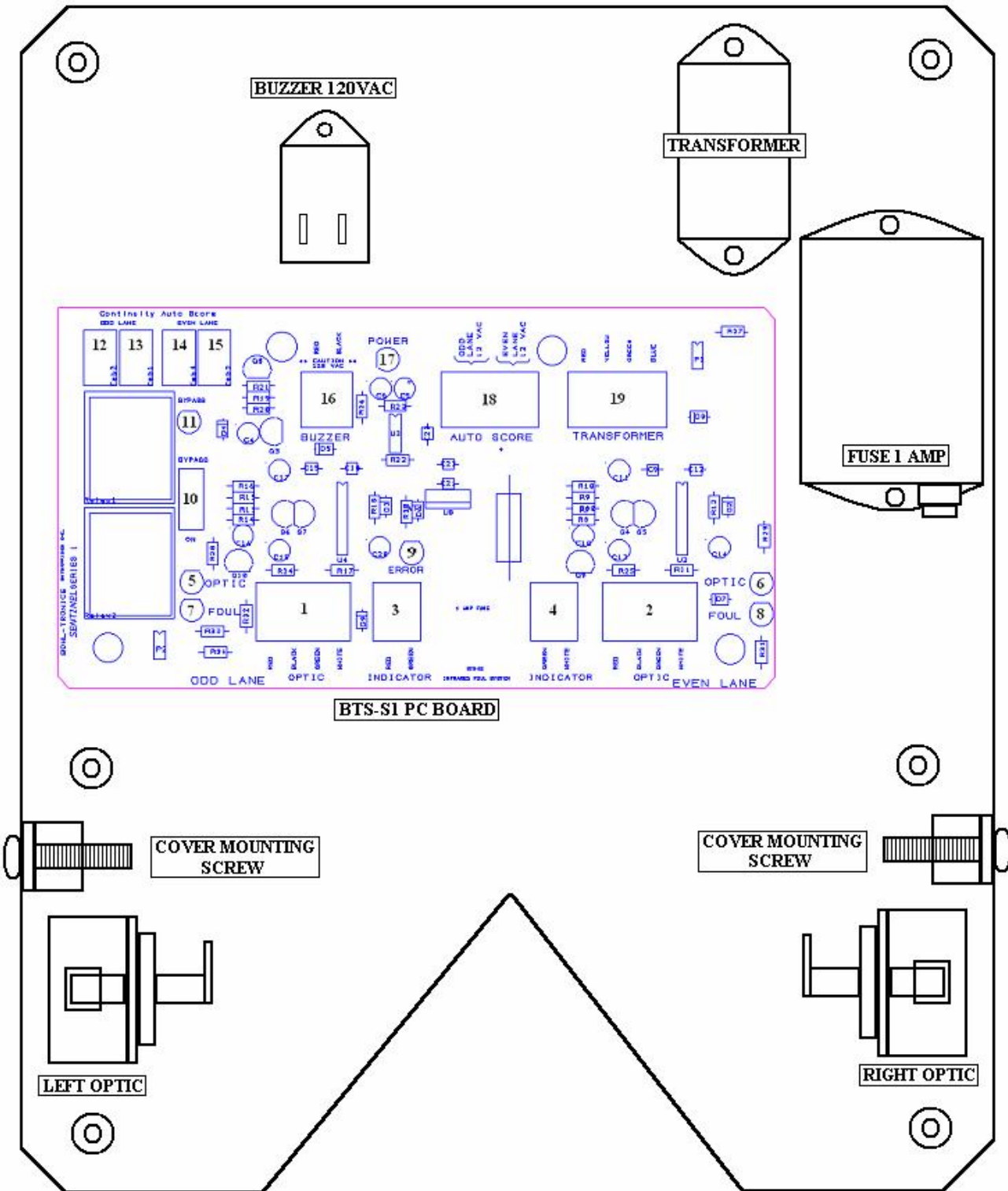

**AMF large division cover foul units**

# ◆BTS-S1 Infrared Foul Unit Manual◆

---

## Theory of Operation

---

The BTS-S1 works on a simple principle. An infrared beam is projected across the foul line which is then reflected back to the unit. When a bowler crosses the foul line the foul unit detects this and turns on the indicator light for that lane and also activates the buzzer. There is approximately a 150 millisecond delay on the detection circuit to allow for the ball to break the infrared beam. As the foul unit turns on the indicator light it also signals the scoring system letting it know that a bowler has fouled.

The foul unit consists of one main PC board that makes it very easy to install and maintain. All of the switching functions that the board performs are done by way of solid state switching. With this method many years of functionality are added to the foul unit. It is not uncommon for a BOWL-TRONICS Foul Unit to operate for many years without being serviced.

## Error Indicator LED

---

The error indicator LED lights up if a short has occurred on either the indicator light sockets shown on the PC board layout description table #3 and #4 or the autoscore output connector shown on the PC board layout description table #18. To remedy this problem, first find where the short is and correct it. Then replace the blown fuse with a 1 AMP 2AGC fuse.

## Bypass Switch

---

The bypass switch allows you to install the foul unit and set it up without having the foul unit be active. When installing the foul unit it should be in bypass mode and the bypass LED should be lit as shown on the PC board layout description table #11. When the installation is complete, slide the switch to the on position and test for proper operation.

## Power Pack

---

On special orders for bowling centers that don't have 120 VAC at there foul line, a power pack will be supplied that mounts on your curtain wall by the machine and a 75' cable mass that runs from the foul unit to the back and plugs into the power pack. (See page #9). Follow the diagram for power connections but utilize the Installation Instructions on the next several pages for the rest of the installation.

# ◆ Installation Instructions ◆

*Remember to remove power before performing any installation!!*

## Replacing Brunswick Large Division and Narrow Large Division Covered Foul Units

After removing the power going to the foul unit, remove the large division cover. Mark and save the wires that run to the back. These are your autoscore connections. Remove the old foul unit and replace it with the new BTS-S1 Foul Unit. For most centers there will be a screw type cannon plug for the power. If your center has this type you just screw it onto the corresponding cannon plug on the BTS-S1 Unit. If your center does not have this type, a black cable will be supplied with the unit for the power connections (*See page #8*). Be sure to have the bypass switch in bypass mode and restore power. Position the Foul Unit with the optic tubes centered on the front edge of the foul line. Use the optic alignment LED's to align the optics as shown on the PC board layout description table #5 and #6. The LED's will be lit when the optics are aligned. Fasten the unit down with the screws provided. Mount the indicator lights just in front of the foul unit. Install the reflectors under the small division covers across from the foul unit with the new ones provided. These are special high output reflectors and should be used with the BTS-S1 Foul Unit. Consult the autoscore section of this manual for all autoscore connections. After connecting you're scoring to the foul unit, slide the bypass switch to on and test for proper operation. On the inside of the cover where the infrared beam is transmitted through it is recommended that you paint around this area flat black. Painting two inches around these holes should be sufficient; this prevents any light from being reflected back off the inside of the cover.

## Replacing AMF Radaray 82-68, 94, 120, & 1000 Foul Units

After removing the power going to the foul unit, remove the large division cover. Mark and save the wires that run to the back. These are your autoscore and machine connections. Remove the old foul unit and replace it with the new BTS-S1 Foul Unit. A black power cable will be supplied with the unit for the power connections (*See page #8*). Be sure to have the bypass switch in bypass mode and restore power. Position the Foul Unit with the optic tubes centered on the front edge of the foul line. Use the optic alignment LED's to align the optics as shown on the PC board layout description table #5 and #6. The LED's will be lit when the optics are aligned. Fasten the unit down with the screws provided. Install the reflectors under the small division covers across from the foul unit with the new ones provided (see illustration on next page). These are special high output reflectors and should be used with the BTS-S1 Foul Unit. Consult the autoscore section of this manual for all autoscore connections. After connecting you're scoring to the foul unit, slide the bypass switch to on and test for proper operation. On the inside of the cover where the infrared beam is transmitted through it is recommended that you paint around this area flat black. Painting two inches around these holes should be sufficient; this prevents any light from being reflected back off the inside of the cover.

The connection for the 82-70 Machine is in the "TB Box" or "AMC Box", these connections are most likely already made but if they are not the hookup is as follows:

*Note: View the PC board layout description table #18 for hook up.*

<u>BTS-S1 Foul Unit</u>		<u>Wires running to back</u>
Autoscore odd	↔	Odd terminal #8
Autoscore odd	↔	Odd terminal #7
Autoscore even	↔	Even terminal #8
Autoscore even	↔	Even terminal #7

**The connections for the 82-30 machine are in the "J Box".** The outputs from the foul unit hook to a 12 volt relay inside. The points of the relay connect to J39 and J1. Closing these points will energize the PR3 Relay, turn on the foul light bulb and put the machine into a foul cycle. Connect the autoscore outputs shown on the PC board layout description table #18 from the foul unit to the coil of the relay. View the schematic diagram below for further information. If you don't have this relay you can purchase one from Bowl-Tronics, Part # FCR or connect the autoscore outputs to a 12 VAC light bulb direct.

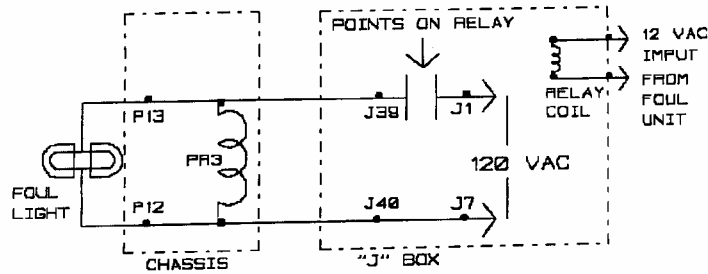

Remove the old lens and housing from the small division cap across from the unit and mount the reflector as shown in the illustration below.

Pop fit the new reflector on the inside of the cover with the curved side facing forward.

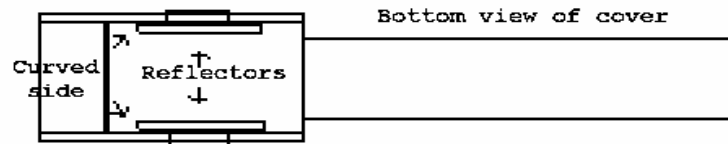

**Reflector installation illustration**

## Replacing All Large Division Foul Units

After removing the power going to the foul unit, remove the large division cover. Mark and save the wires that run to the back. These are your autoscore and machine connections. Remove the old foul unit and replace it with the new BTS-S1 Foul Unit. A black power cable will be supplied with the unit for the power connections (See page #8). Be sure to have the bypass switch in bypass mode and restore power. Position the Foul Unit with the optic tubes centered on the front edge of the foul line. Use the optic alignment LED's to align the optics as shown on the PC board layout description table #5 and #6. The LED's will be lit when the optics are aligned. Fasten the unit down with the screws provided. Mount the indicator lights just in front of the foul unit. Install the reflectors under the small division covers across from the foul unit with the new ones provided. These are special high output reflectors and should be used with the BTS-S1 Foul Unit. Consult the autoscore section of this manual for all autoscore connections. After connecting you're scoring to the foul unit, slide the bypass switch to on and test for proper operation. On the inside of the cover where the infrared beam is transmitted through it is recommended that you paint around this area flat black. Painting two inches around these holes should be sufficient; this prevents any light from being reflected back off the inside of the cover.

# ◆ Power Connections for Foul Units ◆

*Remove the power before making electrical connections!  
Take care in making these connections as damage to the unit can result if done improperly!*

Electrical power requirements for foul units are 120 vac @ 50/60 Hz (220 VAC on special order) There will be a black three wire cable plug coming from the foul unit or the powerpack. It is recommended that the power cord be fastened to the woodwork to prevent damage. All centers that are not equipped with power up front will have a powerpack included with the foul unit. The powerpack should always be installed where the old foul unit was. The connections of the power cable from either the powerpack or the foul unit to the electrical box are as follows.

From Unit		from Electrical Box
Brown	↔	White
Blue	↔	Black
Green	↔	Green or chassis ground

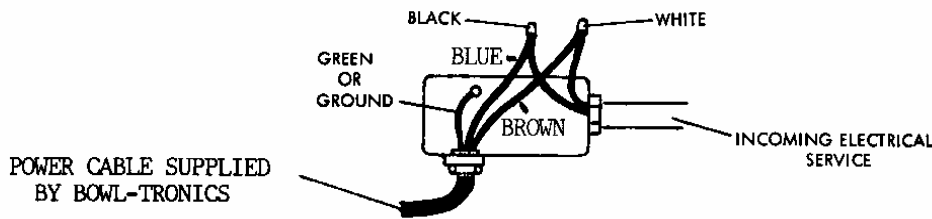

## JUNCTION BOX LOCATIONS & POWER CABLE ROUTINGS

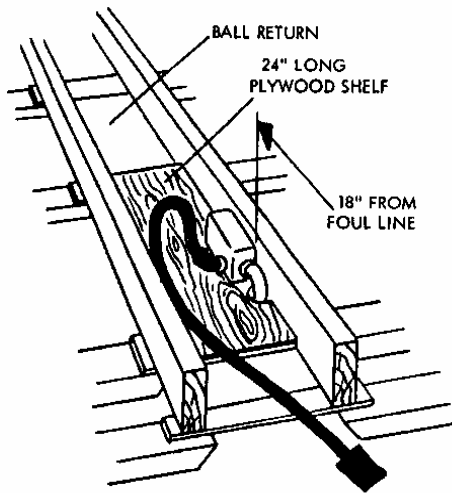

SUGGESTED METHOD OF WIRING FOR SUBWAY BALL RETURN

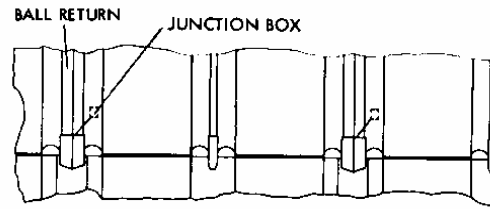

SUBWAY BALL RETURN

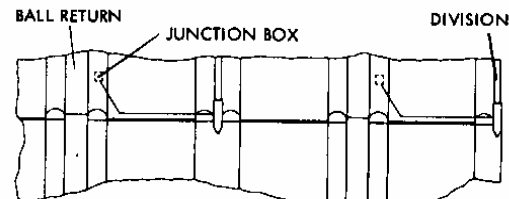

CONCEALED SURFACE BALL RETURN

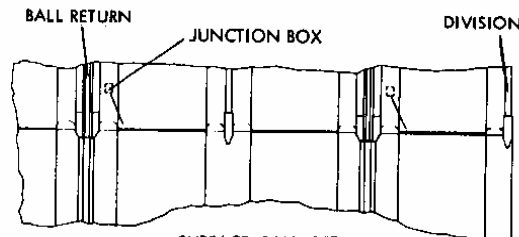

SURFACE BALL RETURN

# ◆ Power Pack Connections for Foul Units ◆

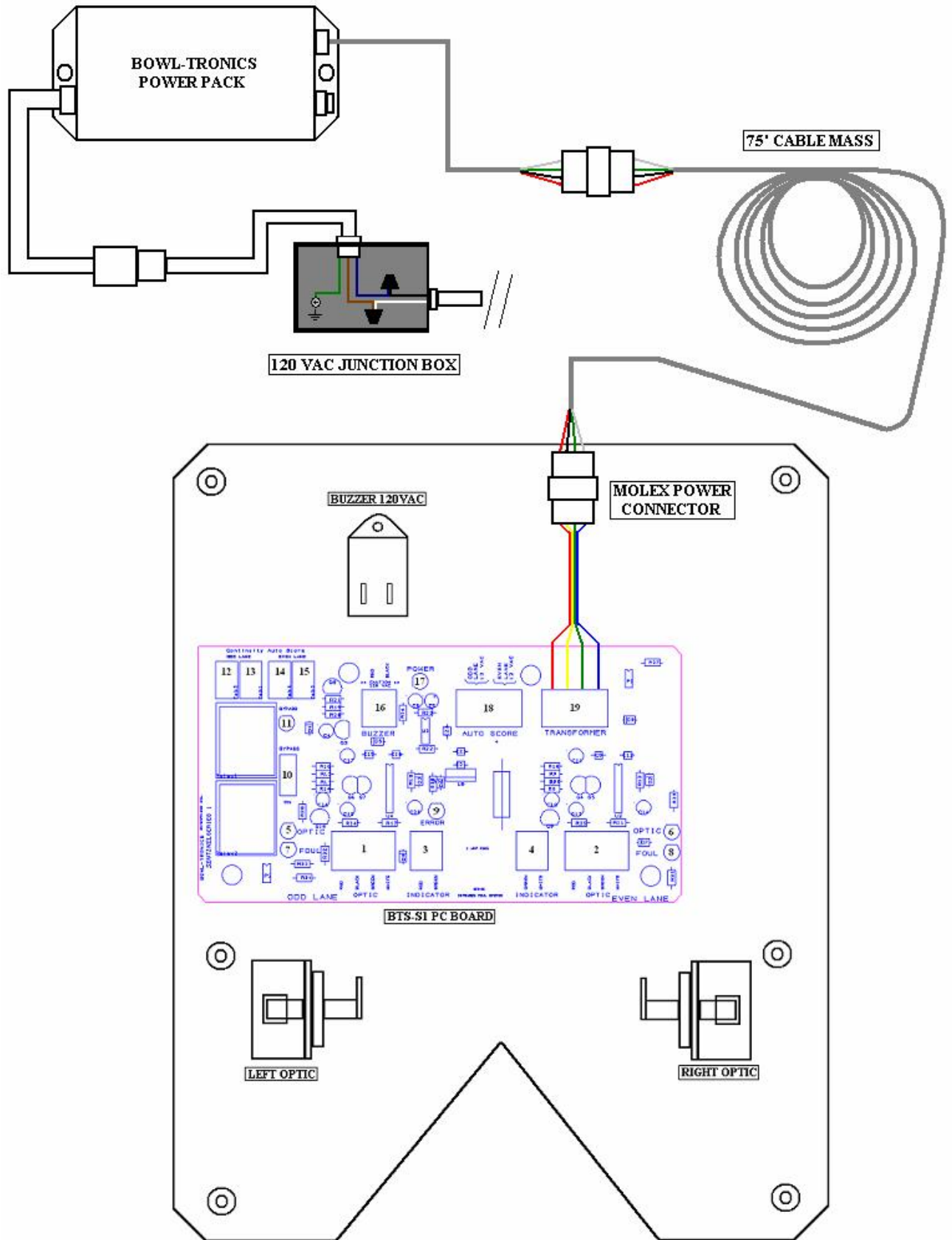

## ◆ Installing New Covers ◆

The approach should be flush with the pit side of the foul line. Notch anchor strips as shown and install the mounting board. The top of the mounting board should be flush with the top of the approach. (See Figure # 1 below)

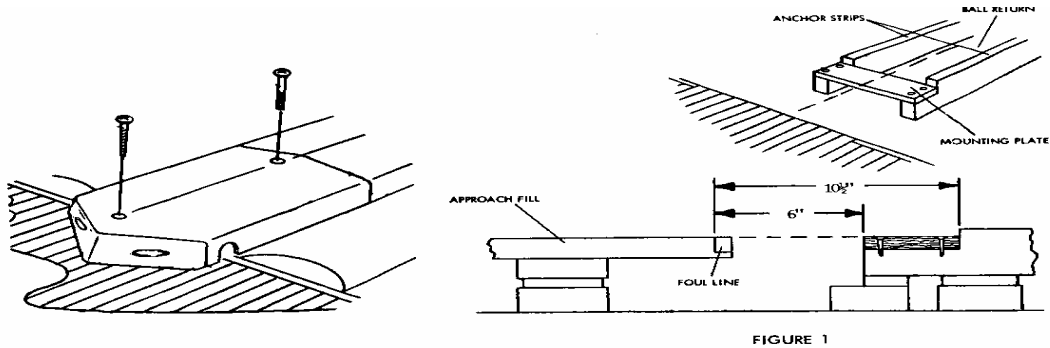

FIGURE 1

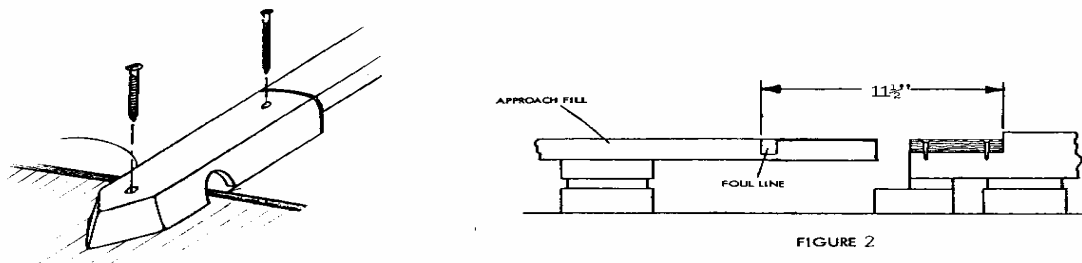

FIGURE 2

## ◆ Autoscore Section ◆

All BTS-S1 Foul Units will come with autoscore outputs. If the center has Brunswick or Computerscore you will utilize the tab connectors shown on the PC board layout description table #12 through #15. Terminals #12 and #13 are you're odd relay point closure outputs and terminals #14 and #15 are you're even relay point closure outputs. All other autoscore systems to date require a 12 VAC output as shown on the PC board layout description table #18.

### Brunswick and Computerscore autoscore hook up

<u>From BTS-S1 Foul Unit</u>	⇔	<u>To Scoring</u>
Tab #12	⇔	Odd lane input
Tab #13	⇔	Odd lane input
Tab #14	⇔	Even lane input
Tab #15	⇔	Even lane input

Note! On Brunswick scoring there's usually a white plastic type connector on the cable assembly called a Molex connector. If you wish to utilize that connector you can order an interface cable part #MIC or cut the connector off and hook directly to the BTS-S1 foul unit.

### All other autoscore hook up

<u>From BTS-S1 Foul Unit</u>	⇔	<u>To Scoring</u>
Odd lane 12 VAC	⇔	Odd lane input 12 VAC
Odd lane 12 VAC	⇔	Odd lane input 12 VAC
Even lane 12 VAC	⇔	Even lane input 12 VAC
Even lane 12 VAC	⇔	Even lane input 12 VAC

