

Bowl-Tronics Enterprises Incorporated

Address: 1115 Sherwood Ave
 Elgin IL. 60120
 Web site: www.bowl-tronics.com
 E-mail: rick@bowl-tronics.com

Phone: 847-741-4500
 Fax: 847-741-0914

◆ Bowl-Tronics Evolution Series 1 Infrared Triggering ◆

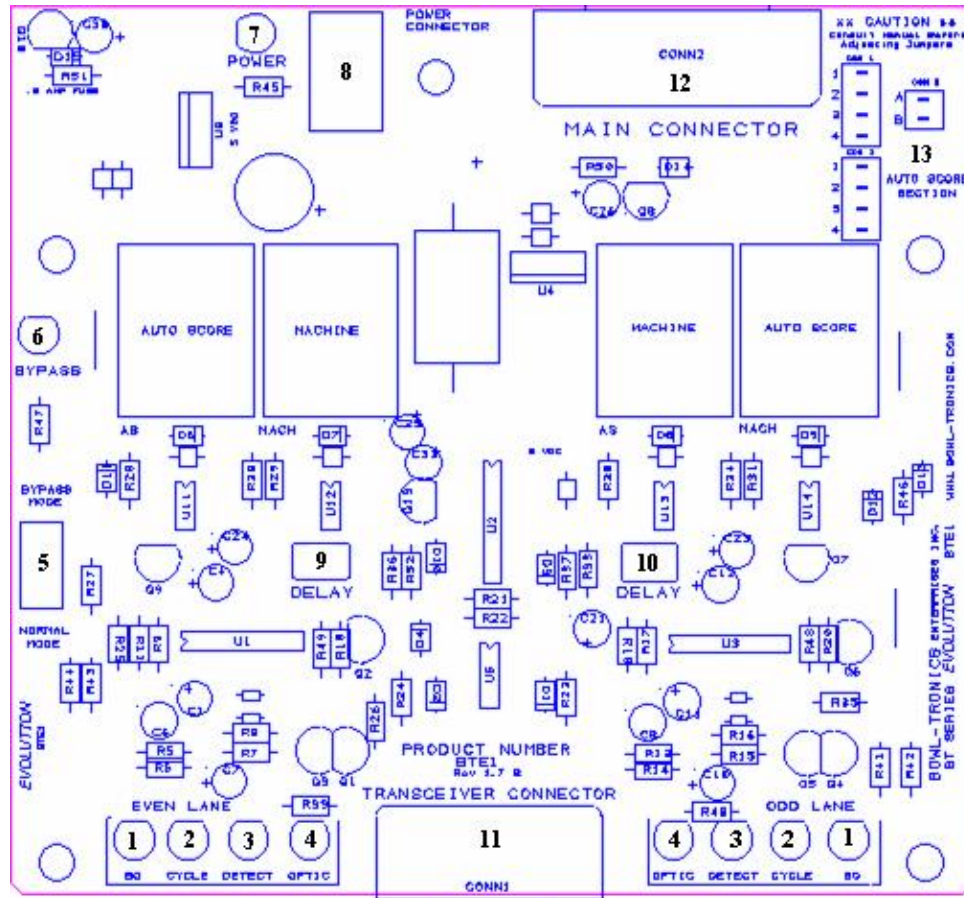

PC Board Layout Description Table:

1. Even/Odd lane Block out Switch LED
2. Even/Odd machine cycle LED
3. Even/Odd initial ball detect LED
4. Even/Odd optic alignment LED
5. Bypass mode & Normal mode switch (*see manual for details*)
6. Bypass switch “active” LED
7. Main power LED
8. Main power receptacle
9. Even lane time delay adjustment
10. Odd lane time delay adjustment
11. DB-9 Transceiver/Optic main connector
12. DB-15 Machine/Scoring main output connector
13. Autoscore Jumper Selection Grid (***CAUTION: CONSULT MANUAL!***)

◆ BTE-S1 Installation Guide ◆

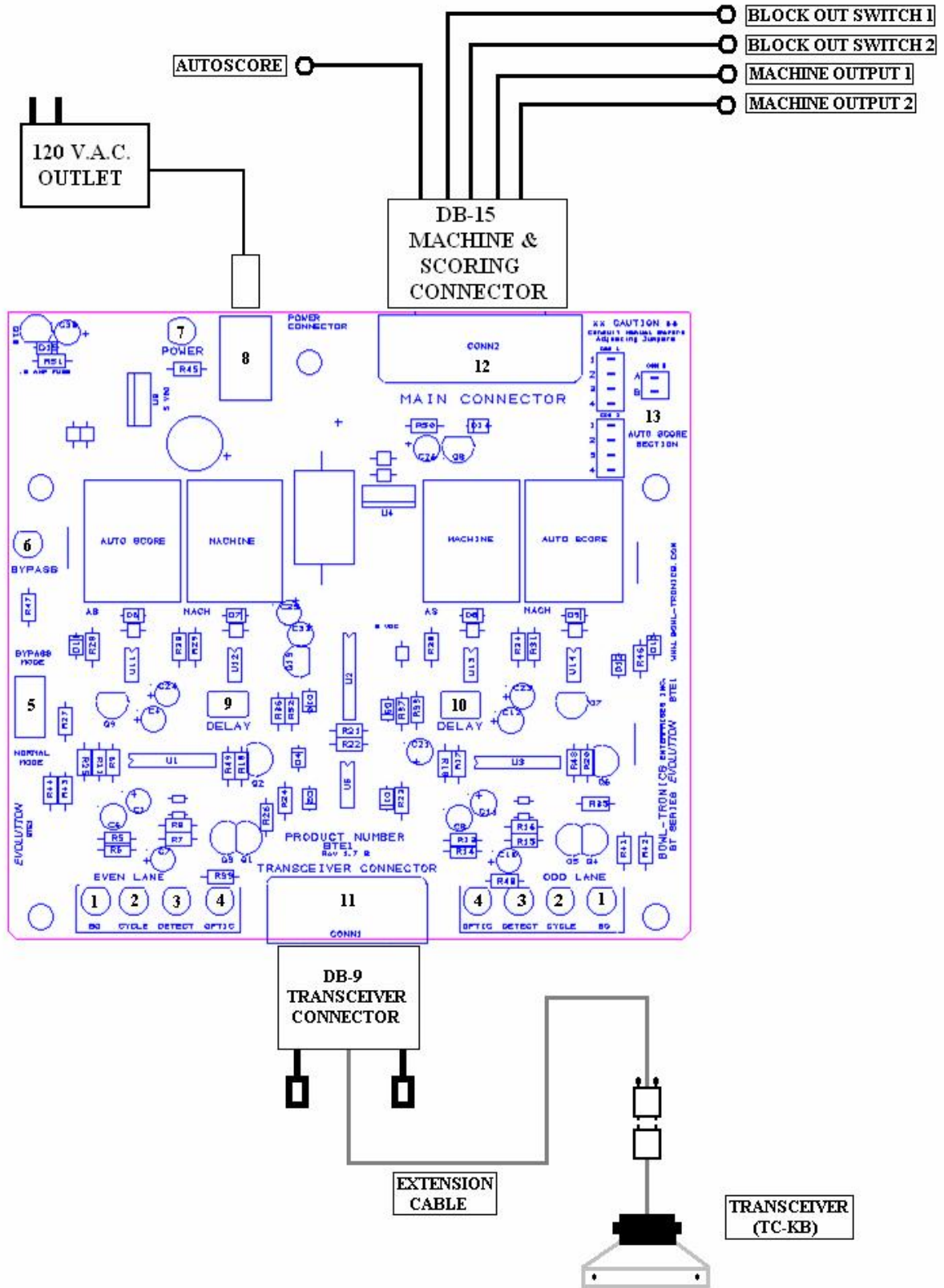

◆ BTE-S1 Infrared Triggering Unit ◆

Theory of Operation

The BTE-S1 consists of two main parts, the Main Circuit Board (BTE-S1 PC) and Transceiver (TC-KB, TC-SUB or TC-SUR). When a ball breaks the infrared beam, the Transceiver sends a signal to the Main Circuit Board telling it a ball has passed. After processing the signal and after an adjustable amount of time, the Main Circuit Board tells the relay to cycle the machine. At some point in time during this operation the Main Circuit Board will also signal your scorer with the proper signal it needs to start the scoring process. When this signal is sent, and the type of signal, depends on the particular scoring system your center has.

Autoscore Jumper Selection Grid (*ATTENTION!*) (*CAUTION!*)

The jumper selections that are on the upper right side of the Main Circuit Board are factory set (depending on what type of scoring exists). Altering these jumper selections can cause extensive damage to the Main Circuit Board. If there is a change in the type of Automatic Scoring please consult Bowl-Tronics tech support department before making changes.

Bypass Mode Switch

The Bypass Mode Switch does two functions. First, it is used to test the alignment of the Transceiver without having the BTE-S1 system be active. In the bypass mode position the LED will be lit and will not trigger the machine or your automatic scoring so you can test the optics for proper alignment. Second, it is a safety switch, so when a service call occurs you can safely shut down the BTE-S1 triggering to fix the machine problem.

Transceiver (TC-KB, TC-SUB or TC-SUR)

The Transceiver contains the phototransistors and Infrared Emitting Diodes. When mounted on the kickback or capping, the Transceiver projects a beam of infrared light across the lane which is reflected back by the reflector. When a ball breaks this beam the Transceiver sends a signal to the Main Circuit Board letting it know a ball has passed the beam. The strength of the infrared signal can be seen on the bottom of the BTE-S1 circuit board labeled LED #4 on the PC Board Layout Description Table or by the LED's on the Transceiver itself. Two LED's, one for each lane, will light when the infrared signal reaches 85% of the maximum value. These LED's help properly align the Transceiver.

Block out Switches (optional)

The Block out Switches, which are only used on Brunswick machines, are micro switches that mount on the 4 to 1 shaft of the gear box. When the machine cycles the Block out Switch closes. This effectively disables the BTE-S1 from triggering the machine a second time. Two LED's, one for each lane labeled LED #1 on the PC Board Layout Description Table should not be lit when the machine is at idle. When the machine starts the LED should be lit and stay lit until the machine is at idle again. If the switch is malfunctioning you could get consecutive triggering to occur. These LED's are very useful when trouble shooting Block out Switch malfunctions.

◆ Installation Instructions ◆

Before Performing Any Installation Make Sure That Power Is Removed From the Machine By Unplugging The Power Cord From The Electrical Chassis!!

Mounting the BTE-S1

The BTE-S1 Triggering mounts on the curtain wall, between the pair of machines, just above the masking unit. A power pack is provided with your BTE-S1 that plugs into a 120 volt outlet located on the curtain wall. Remove the cover from the BTE-S1 and set aside. Please refer to the installation guide on page two when installing your BTE-S1. After the BTE-S1 is mounted on the curtain wall consult the instructions for your particular machine. Replace cover when installation is complete.

Brunswick Machine Installation

The Model A-2 Machine

Once your BTE-S1 is mounted on the curtain wall, run the two output cables from the DB-15 connector labeled #12 on the PC Board Layout Description Table to each machines electrical control chassis. These cables are marked with a red label to signify that they're the machine output cables. One output cable will be labeled "1", this is for the left or odd machine (1, 3, 5, etc.). The other output cable will run to the right or even machine labeled "2" (2, 4, 6, etc.). Run each output cable to the time delay module inside your electrical chassis. The red wire will connect to terminal #16 on your time delay module using the dual tab connector supplied with your BTE-S1. The black wire will connect to terminal #18 on your time delay module, also using the dual tab connector. Leave the wires that are already connected to the time delay module. *Note!! You must leave your rake trigger switch connected to the time delay module. If you don't have a rake trigger switch, hook the red wire to terminal #16 and your black wire to terminal #17.*

Mount the Transceiver on the kickback or capping (see page #12 illustrations) and the reflector straight across from it. The signal strength indicator LED's should be lit up if everything is mounted straight. Also, try to mount all Transceivers and reflectors in a straight line all the way across your bowling center. Mounting everything straight and level can solve many problems in the future. A string run across the bowling center can be an easy guide for mounting Transceivers and reflectors. The Transceiver will have a male DB-9 connector which plugs into the corresponding female DB-9 extension cable. The extension cable's other end is a DB-9 male connector which plugs into the corresponding female DB-9 connector on the BTE-S1, labeled #11 on the PC Board Layout Description Table.

If your BTE-S1 has Block out Switches mount them on the 4 to 1 shaft of the gear box (see page #11, illustration #1). The two, two wire cables from the Block out Switches each run to the BTE-S1's DB-15 connector labeled #12 on the PC Board Layout Description Table. These cables are marked with a blue label to signify that there the Block out Switch cables. Make sure the cable marked "1" is on the odd numbered machine (1, 3, 5, etc.)

You can now plug in the power pack to the 120 Volt outlet on the curtain wall. The cable from the power pack then runs to the BTE-S1 and plugs into the main power connector labeled #8 on the PC Board Layout Description Table. *Be sure to have the Bypass Mode Switch in bypass mode. to properly align the Transceiver discussed earlier in this section. When completed, switch bypass switch to normal mode and test.*

◆ For all autoscore hookups please consult the autoscore section of this manual ◆

The Model A Machine

Once your BTE-S1 is mounted on the curtain wall, run the two output cables from the DB-15 connector labeled #12 on the PC Board Layout Description Table to each machine's electrical control chassis. These cables are marked with a red label to signify that they're the machine output cables. One output cable will be labeled "1", this is for the left or odd machine (1, 3, 5, etc.). The other output cable will run to the right or even machine labeled "2" (2, 4, 6, etc.). Connect the red wire to terminal #1 on the low voltage terminal strip and the black wire to terminal #11, also on the low voltage terminal strip.

Mount the Transceiver on the kickback or capping (see page #12 illustrations) and the reflector straight across from it. The signal strength indicator LED's should be lit up if everything is mounted straight. Also, try to mount all Transceivers and reflectors in a straight line all the way across your bowling center. Mounting everything straight and level can solve many problems in the future. A string run across the bowling center can be an easy guide for mounting Transceivers and reflectors. The Transceiver will have a male DB-9 connector which plugs into the corresponding female DB-9 extension cable. The extension cable's other end is a DB-9 male connector which plugs into the corresponding female DB-9 connector on the BTE-S1, labeled #11 on the PC Board Layout Description Table.

If your BTE-S1 has Block out Switches mount them on the 4 to 1 shaft of the gear box (see page #11, illustration #1). The two, two wire cables from the Block out Switches each run to the BTE-S1's DB-15 connector labeled #12 on the PC Board Layout Description Table. These cables are marked with a blue label to signify that these are the Block out Switch cables. Make sure the cable marked "1" is on the odd numbered Machine (1, 3, 5, etc.)

You can now plug in the power pack to the 120 Volt outlet on the curtain wall. The cable from the power pack then runs to the BTE-S1 and plugs into the main power connector labeled #8 on the PC Board Layout Description Table. Be sure to have the Bypass Mode Switch in bypass mode to properly align the Transceiver discussed earlier in this section. When completed, switch bypass switch to normal mode and test.

It is recommended that the cycle solenoid on the A machine be modified so it will not pull as hard on the trip link. This can be accomplished by placing a stop bracket in front of the plunger (see page #11, illustration #2). Drill a hole in the solenoid mounting bracket in front of the plunger. Then, mount the stop bracket and slide the plunger into the solenoid until it just starts to pull on the trip latch. Next, slide the stop bracket up to the plunger and tighten it down. This method keeps the plunger from coming all the way out. With the plunger's travel distance cut down it won't pull as hard, cutting down on wear and tear on both the solenoid and the trip latch. The reason for this modification is that the cycle solenoid was not engineered to withstand energizing every cycle. This modification will add many years to the life of your cycle solenoid.

(Note!!!! If installing a Bowl-Tronics 24 VAC solenoid assembly instead of the BRC (A) high voltage solenoid follow these directions.) First, remove the high voltage solenoid and replace with the new 24 VAC solenoid w/bracket. Second, feed the new 2 conductor SJOW cable into the chassis and hook one wire to terminal #9 and the other wire to terminal #11.

◆ For all autoscore hookups please consult the autoscore section of this manual ◆

AMF Machine Installation

Installation for all AMF Machines

Once your BTE-S1 is mounted on the curtain wall, run the two output cables from the DB-15 connector labeled #12 on the PC Board Layout Description Table to each machine's tenth frame switch inside the TBA or AMC box, depending on what type of machine you have. These cables are marked with a red label to signify that they're the machine output cables. One output cable will be labeled "1", this is for the left or odd machine (1, 3, 5, etc.). The other output cable will run to the right or even machine labeled "2" (2, 4, 6, etc.) Hook each output cable in parallel with the tenth frame reset switch. The colors of the wires do not matter, as this is just point closure.

Mount the Transceiver on the front of the kickback or capping (see page #12 illustrations) and the reflector straight across from it. The signal strength indicator LED's should be lit up if everything is mounted straight. Also, try to mount all Transceivers and reflectors in a straight line all the way across your bowling center. Mounting everything straight and level can solve many problems in the future. A string run across the bowling center can be an easy guide for mounting Transceivers and reflectors. The Transceiver will have a male DB-9 connector which plugs into the corresponding female DB-9 extension cable. The extension cable's other end is a DB-9 male connector which plugs into the corresponding female DB-9 connector on the BTE-S1, labeled #11 on the PC Board Layout Description Table.

You can now plug in the power pack to the 120 Volt outlet on the curtain wall. The cable from the power pack then runs to the BTE-S1 and plugs into the main power connector labeled #8 on the PC Board Layout Description Table. Be sure to have the Bypass Mode Switch in bypass mode to properly align the Transceiver discussed earlier in this section. When completed, switch bypass switch to normal mode and test.

◆ For all autoscore hookups please consult the autoscore section of this manual ◆

(Bottom intentionally left blank)

◆ Autoscore Section ◆

Connecting Your Scoring

After connecting all of the other wires to your machine and BTE-S1 follow the instructions for your particular type of scoring and machine. Take care in making your autoscore connections, as this can help speed up the process and minimize scoring problems.

AMF Autoscore with K-1 Relays on Brunswick Machines

The two wire machine output cables are marked with a red label to signify that they're the machine output cables. One output cable will be labeled "1", this is for the left or odd machine (1, 3, 5, etc.). The other output cable will run to the right or even machine labeled "2" (2, 4, 6, etc.). These wires run to the electrical chassis and hook into the K-1 relay instead of the low voltage terminal strip or the time delay module. The connection will be in parallel with the time delay relay. Make connections as follows:

- Red wire ⇒ Terminal 5 on the K-1 Relay
- Black wire ⇒ Terminal 8 on the K-1 Relay

AMF Magicscore on Brunswick Machines

There will be a white labeled three conductor autoscore cable from the DB-15 connector labeled #12 on the PC Board Layout Description Table, colored Red, Black, and White. This will supply the scoring with 12 volts DC APS Output. The black and white wires will switch ground on and off when a ball passes the Transceiver.

We also recommend that you replace the AMF Time Delay Module and install a new solid state relay for cycling of the machine.

- Red wire ⇒ 12 VDC (common)
- White wire ⇒ Right Output
- Black wire ⇒ Left Output

AMF Accuscore on Brunswick or AMF Machines

There will be a white labeled four conductor autoscore cable from the DB-15 connector labeled #12 on the PC Board Layout Description Table. At the end of the cable there will be an interface adapter card with red and black wires for the odd machine, while the green and white wires are for the even machine.

- On Brunswick machines tie the wires in where the old APS Relay points were
- On AMF machines tie the wires parallel to the rake start switch

Brunswick Autoscore on Brunswick or AMF Machines

AS-80 w/79 Scanners

There will be a white labeled three conductor autoscore cable from the DB-15 connector labeled #12 on the PC Board Layout Description Table. At the end of the cable there will be an interface adapter card with a white Molex connector on the end. The Molex connector connects to the DA Board in place of the old optics. The BTE-S1 adapter card takes 5 volts dc from the DA board and sends it back to the DA board for both right and left ball detect. When a ball passes the Transceiver the 5 volts dc will drop to zero and start the scanner.

- *The time delay for taking data must be set so that the scorer takes data before the table comes down on the pins. If you are still having scoring trouble wire the data take relay as shown in manual. (See page #13)*

AS-90 & Framworx w/86 Scanners or CCD Cameras

There will be a white labeled three conductor autoscore cable from the DB-15 connector labeled #12 on the PC Board Layout Description Table. At the end of the cable there will be an interface adapter card with 2 white Molex connectors on the end. Red, Black, and White are for the left optic and Orange, Blue, and Yellow are for the right optic. These will replace both sets off Brunswick's infrared optics. Note!! If you have 86 Scanners the hook up is the same except there will only be Red and Black wire for the left optic and Orange and Blue wire for the right optic. With this setup you will need only one optical head per pair. This hook up is optional and the BTE-S1 outputs can be used as either the main or as a backup. This system takes 5 volts dc from Brunswick's optic cable and sends it to the camera. This voltage is kept off until a ball passes the Transceiver, at which time it rises to 5 volts dc to signal the camera or scanner.

- *The time delay for taking data must be set so that the scorer takes data before the table comes down on the pins. If you are still having scoring trouble wire the data take relay as shown in manual. (See page #13)*

(Bottom intentionally left blank)

◆ Troubleshooting Guide ◆

Troubleshooting the BTE-S1

If a problem arises with your BTE-S1 the easiest way to find the problematic part is to use the diagnostic LED's at the bottom on the Main Circuit Board. Each LED shows what is occurring with each cycle of the machine. Below is a table showing you what each LED is for and it's function.

Diagnostic LED Description Table

LED #	Description	Trouble Shooting Use
4	Even/Odd optic alignment LED	Use this LED if you're having random triggering problems. The LED should be lit if the optic is aligned.
3	Even/Odd initial ball detect LED	Use this LED to verify that the ball is breaking the infrared beam.
2	Even/Odd machine cycle LED	Use this LED to verify that the machine cycle relay is closing on the BTE-S1 Main Circuit Board.
1	Even/Odd lane Block out Switch LED	Use this LED to verify that the Block out Switch is opening and closing normally. The LED should not be lit when the machine is at idle. When the machine starts, the LED should be lit and stay lit until the machine is at idle again. If the switch is malfunctioning consecutive triggering can occur.

You Experience Random Triggering On Either or Both Lanes

- Use the Diagnostic LED Description Table
- Double check your wiring
- Check that the reflector is clean
- Try swapping components you know that work

Basic Troubleshooting

Visually inspect your BTE-S1 to be sure that all proper connections are made. Many problems can be solved by changing the Transceiver and making sure that it is aligned properly. The reflectors also play a large part. If the reflector is dirty it will fail to reflect the infrared beam back to the Transceiver. Also, make sure that the wiring in the machine is correct (especially in Brunswick machines)

As with all electronic goods, parts do fail. At Bowl-Tronics we buy only the highest quality electronic parts available to us. Your BTE-S1 should give you many years of reliable service. If in the event your BTE-S1 does fail to operate correctly, you should call Bowl-Tronics at the number listed on the next page.

◆ Brunswick Illustrations ◆

4 To 1 Block out Switch Mounting On Brunswick Machine

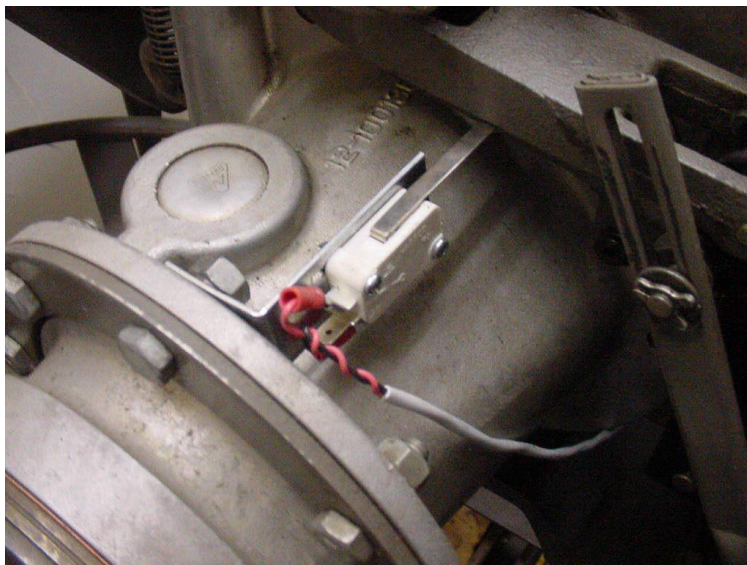
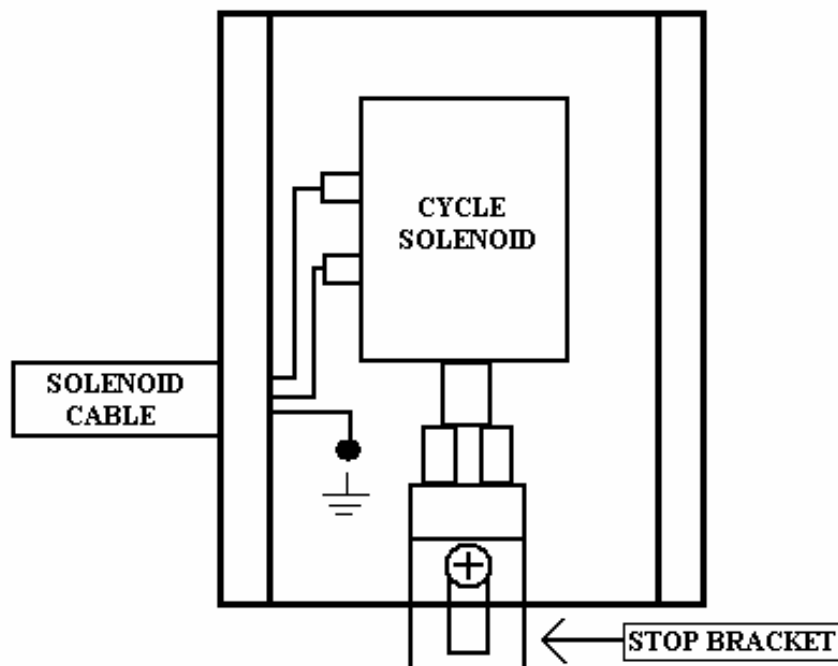

ILLUSTRATION SHOWS LEVER IS DEPRESSED AT 0 DEGREES AT IDLE

Stop Bracket on Brunswick “A” Cycle Solenoid



STOP BRACKET REDUCES THE PLUNGER TRAVEL PREVENTING IT FROM PULLING SO HARD ON THE CLUTCH TRIP LEVER

**MOUNT TRANSCEIVER LEVEL AND STRAIGHT ACROSS FROM REFLECTORS
USE THE LED'S TO ALIGN PROPERLY**

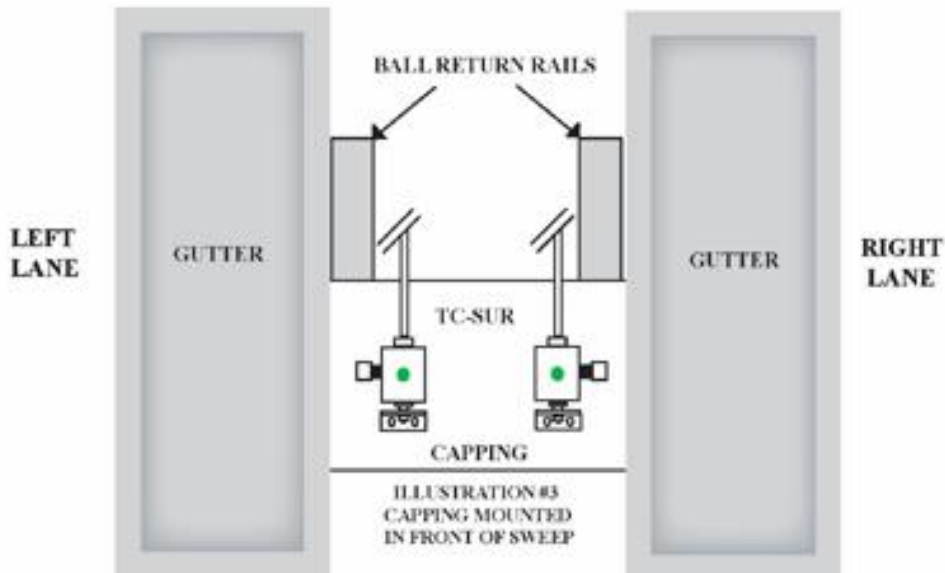
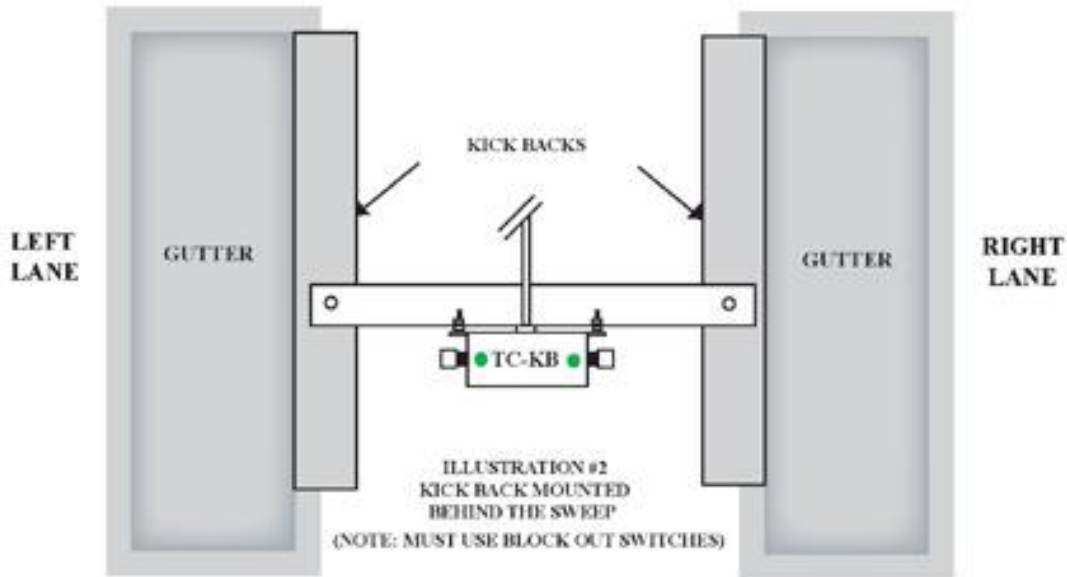
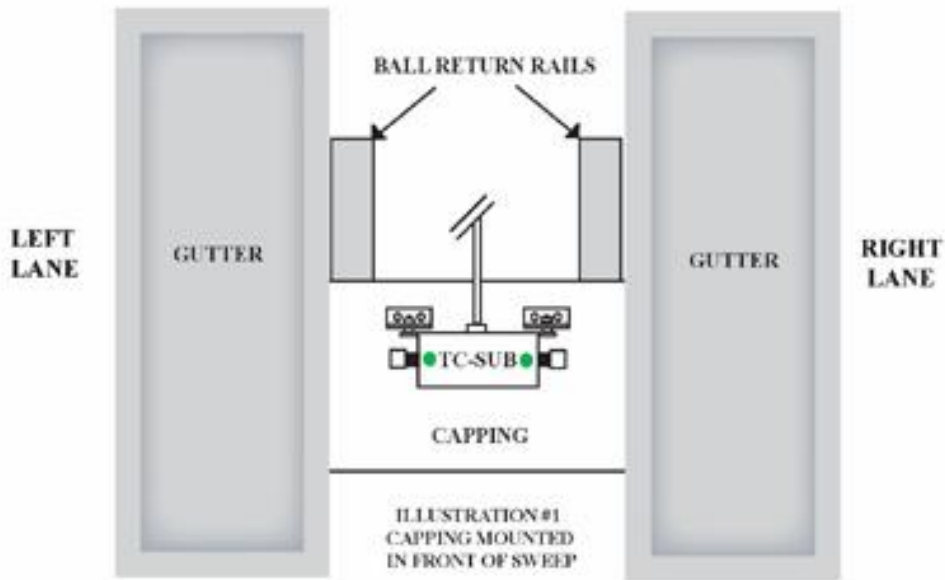

◆ Brunswick Schematic ◆

Data Take Relay Hook Up On Brunswick "A-2" Machine

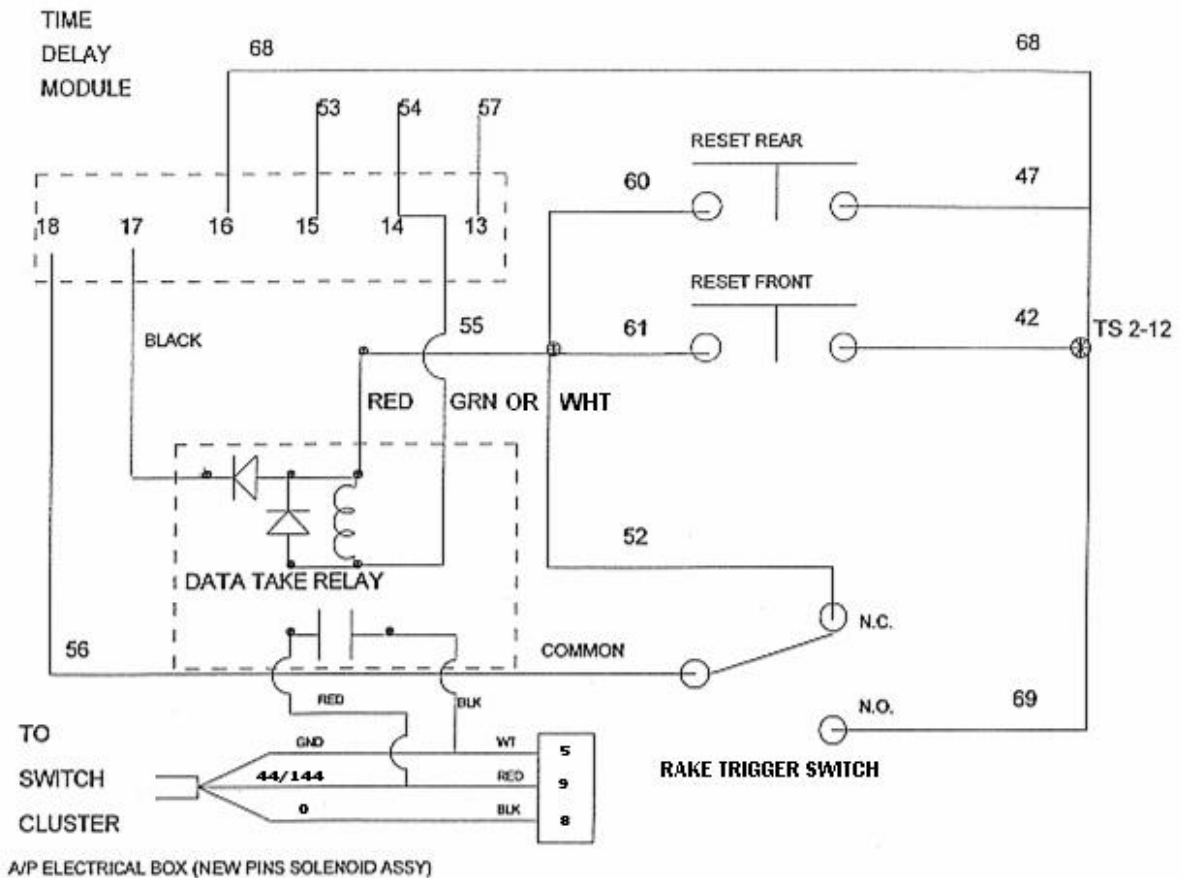

UNPLUG WIRE # 55 OFF TERMINAL 17 ON TIME DELAY MODULE. PLUG BLACK WIRE FROM DATA TAKE RELAY ON TERMINAL 17. PLUG RED WIRE FROM DTR INTO WIRE # 55. PLUG GREEN WIRE FROM DTR INTO TERMINAL # 14 ON TIME DELAY MODULE USING DUAL TAB CONNECTOR.

Data Take Relay Hook Up On Brunswick "A" Machine

