

Bowl-Tronics Enterprises Incorporated

Address: 1115 Sherwood Ave.
Elgin IL. 60120
Website: www.bowl-tronics.com
E-mail: rick@bowl-tronics.com

Phone: 847-741.4500
Fax: 847-741-0914

Ball Lift Motor Control Box (BL120-240 24HD)

Ball Lift Motor Control Box Theory

This ball lift motor control box is designed to replace the existing Brunswick ball lift box or similar ball lift box. On the inside cover of the (BL120-240 24HD) there will be a schematic on how to wire the (BL120-240 24HD), it will also be on the back of this page. From the machine 24 VAC supplies voltage to the solid-state control circuit, this closes the circuit to start your ball lift and hand dryer motor running. Note. The hand dryer motor cable is pre wired in the box to the transformer to give 24 VAC @ 4 amps.

Installation Instructions

Remember to remove power before performing any installation!!

First, start by removing the old ball lift box. Next, you will utilize the main power cable, ball lift motor cable, hand dryer cable and the two sets of low voltage 24 VAC wires from the machine. Start by installing your main power connection to the new (BL120-240 24HD) box. Next, install the ball lift motor cable to the (BL120-240 24HD) box. The hand dryer output will have a 5 ft black SJOW cable which will splice into your hand dryer motor. View the schematic to help wire up all the connections to the (BL120-240 24HD) box. Finally, hook up the 24 VAC low voltage wires to the (BL120-240 24HD) box via the quick disconnect bullet connectors.

For Repair Send Faulty Parts to:

Address: BOWL-TRONICS
1115 Sherwood Ave.
Elgin IL. 60120

Phone: 847-741-4500
Fax: 847-741-0914

Visit our web site at www.bowl-tronics.com

Notes:

Ball Lift Motor Control Box Schematic

BALL LIFT MOTOR CONTROL CHASSIS 120 VAC INPUT

24 VAC HAND DRYER OUTPUT

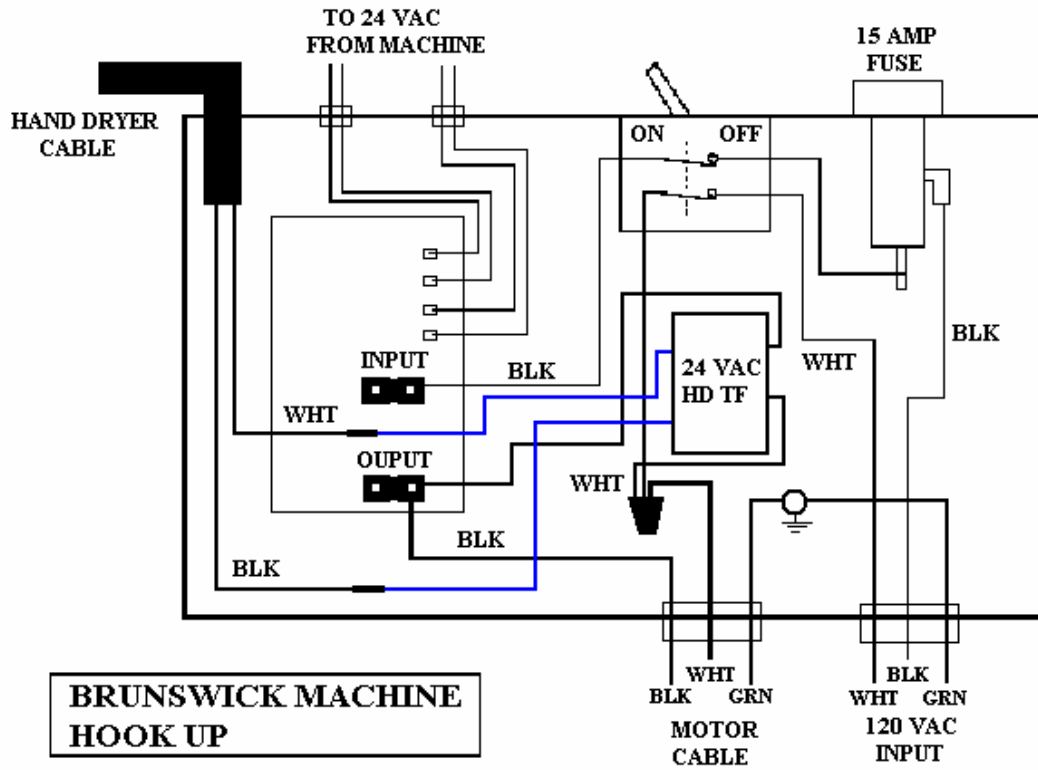

BALL LIFT MOTOR CONTROL CHASSIS 220 VAC INPUT

24 VAC HAND DRYER OUTPUT

